

# DESIGN THROUGH ANALYSIS: SIMULATION-DRIVEN DESIGN SPEEDS SYSTEM LEVEL DESIGN AND TRANSITION TO MANUFACTURING

White Paper

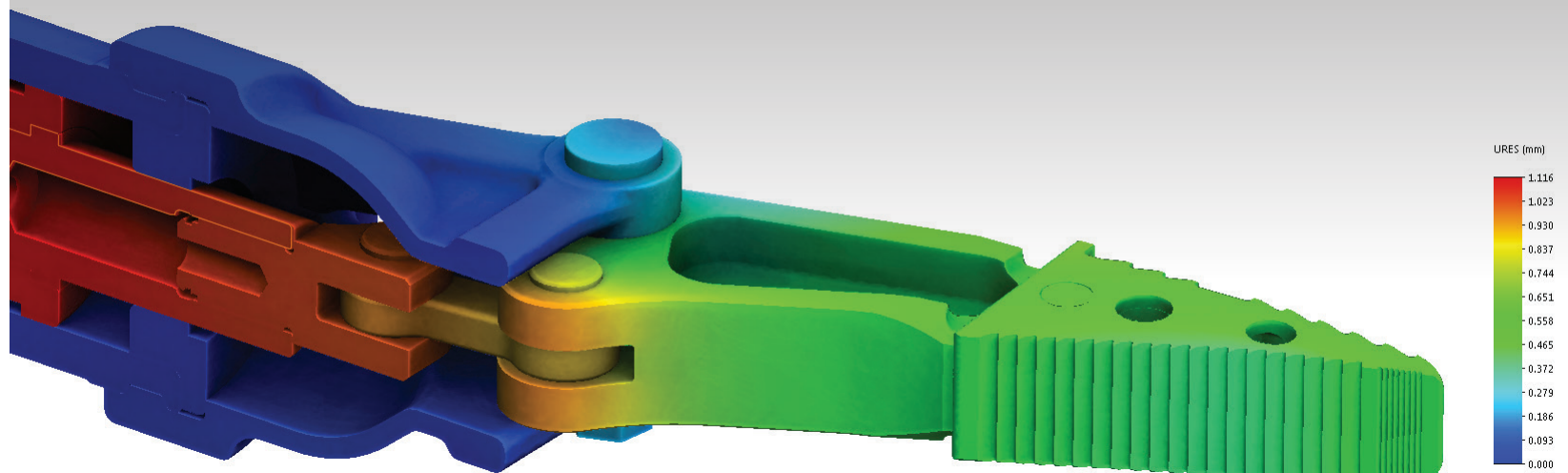

## OVERVIEW

Today's engineers and chief designers, who lead system-level or large assembly design teams, work under increasing pressure to develop more innovative, better-performing, and easier-to-manufacture products more quickly and cost-effectively. As manufacturers pursue strategies that emphasize increased innovation, automation, and throughput across their product development and manufacturing organizations to meet increasing global competition, engineers and chief designers are being tasked with achieving a challenging new set of objectives. Not only are they expected to accelerate system-level and large assembly design efforts, control costs by reducing prototyping and physical testing, and streamline the transition to manufacturing and subsequent production, they are also expected to satisfy all of these goals while also delivering innovative, better-performing products. Fortunately, engineers and chief designers can overcome these challenges by adding robust CAD-integrated simulation and design analysis capabilities to their toolbox. This paper explores the range of new challenges that engineers and chief designers face and how SOLIDWORKS® Simulation Professional analysis software can help them meet their individual and organizational goals.

## MINIMIZING PROTOTYPING, IMPROVING SYSTEM-LEVEL DESIGNS, AND ACCELERATING MANUFACTURING TRANSITION REQUIRES SIMULATION

Global competitive pressures compel successful manufacturers to develop safer, more innovative, higher-quality products more quickly and cost-effectively, which requires everyone associated with product development to do more by working smarter to support more exacting product requirements. For engineers and chief designers, these requirements include eliminating late-cycle design performance and/or manufacturability issues from system-level and large-assembly designs, which can result in lengthy production delays and cost overruns, as well as preventing failures in the field. With less time and money available for resolving these types of issues through physical prototyping/testing, engineering change orders (ECOs), rework, and retrofits, engineers and chief designers face the dilemma of developing higher-quality, better-performing system-level and large assembly designs while simultaneously controlling costs and accelerating time to market.

Because today's successful manufacturers recognize that achieving higher levels of innovation, automation, and throughput is a proven strategy for success, engineers and chief designers need robust, efficient CAD-integrated simulation tools to work smarter in support of this approach. Product development organizations no longer have the luxuries of time and money to throw at design or manufacturing problems, and engineers and chief designers need to further automate the processes required to turn system-level and large-assembly design concepts into innovative, quality products. By automating the upfront evaluation of system-level and large assembly designs through the use of CAD-integrated simulation tools, engineers and chief designers can work more effectively with design team members, both in defining the specifications for a design project and in validating design performance, to achieve higher-quality products.

While designers are tasked with creating innovative design concepts, engineers and chief designers carry the responsibility for transforming these "preliminary" concepts into actual products that can be affordably manufactured and then sold at a profit. Engineers and chief designers work to "productize" design concepts by ensuring that the products based on these designs are safe, perform as intended, and are manufacturable. To boost throughput—increasing the number of system-level and large-assembly design concepts that are "productized" in the same amount of time—engineers and chief designers need the insights and knowledge regarding design performance and manufacturability that were once provided by extended rounds of expensive physical prototyping. CAD-integrated simulation tools like SOLIDWORKS Simulation Professional software can provide access to this type of information in a fraction of the time and cost of traditional prototyping methods, minimizing prototyping, improving design quality, and accelerating the transition to manufacturing.

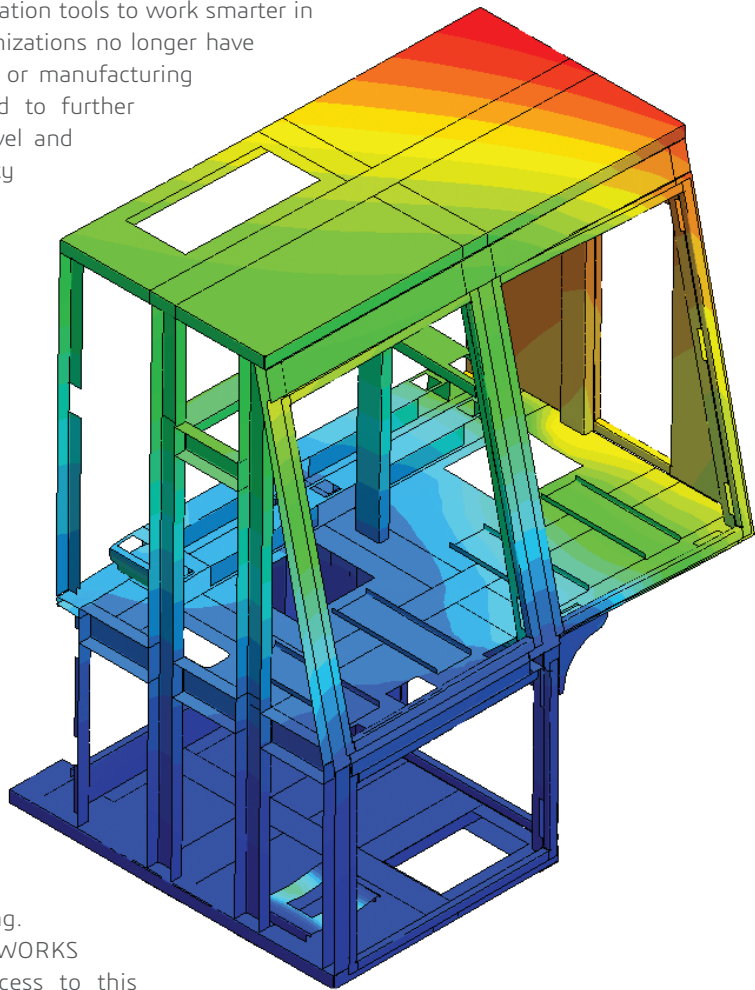

## **FINALIZE, VALIDATE, AND RELEASE BETTER-PERFORMING DESIGNS TO MANUFACTURING MORE QUICKLY WITH INTEGRATED SIMULATION**

In carrying responsibility for productizing design concepts, engineers and chief designers need as much design performance and manufacturability information as they can get—and as early in the process as possible—to effectively manage the development of system-level and large-assembly designs. By validating different types of design behavior and the intended production method during conceptual design, engineers/chief designers can streamline the process of refining early concepts into better-performing, manufacturable products.

### **Managing System-Level/Large Assembly Design Projects**

The role of the engineer/chief designer is in some ways analogous to a conductor of a symphony, with the engineer/chief designer bringing disparate elements—component or subassembly designs developed by different members of the design team—together into a single, unified whole. Engineers/chief designers face a range of challenges in executing this role, and CAD-integrated simulation tools can provide the insights and understanding they need to achieve their product development goals.

### **Establishing Design Parameters**

Whether an engineer/chief designer heads up a team that is working on a single large assembly or a complete mechanical system comprising several assemblies, he or she needs to define both the design space and operating environment—the design parameters—for each part or portion of the design in the form of design specifications for every designer on the team. Specifications based on previous models and operating conditions may not apply to innovative, potentially better-performing concepts, and simulation tools can help engineers and chief designers quickly establish specific design parameters for each member of the design team.

### **Validating Innovative Concepts**

How can an engineer/chief designer simultaneously shorten design cycles and produce innovative products without taking the time and spending the money to prototype and test innovative design ideas and concepts? Innovative designs are often overlooked—mainly to avoid the time and cost of the additional prototyping and testing required to validate them. Instead of sticking with a design or an approach that is familiar, engineers/chief designers can tap CAD-integrated simulation tools to validate innovative concepts without incurring the time and cost of physical prototyping.

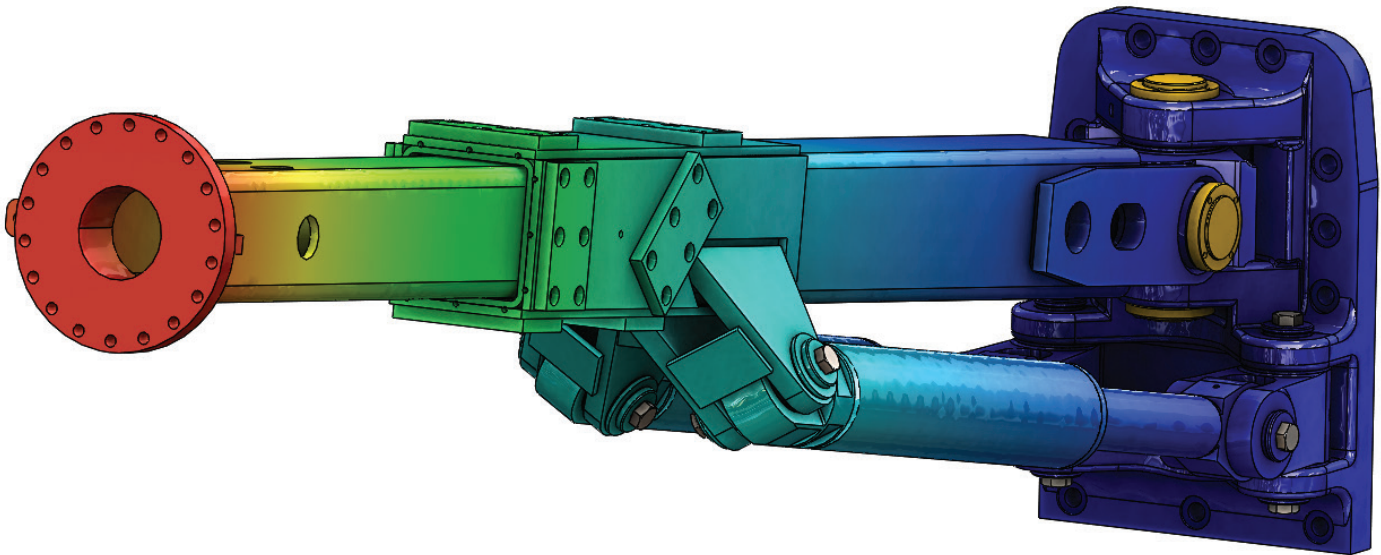

### **Ensuring Product Safety**

A key aspect of productizing design concepts is ensuring that the product will be safe for customers to use, which requires an understanding of how the product will perform under load. Engineers/chief designers either establish specific factors of safety for members of their design teams or instruct team members to over-design their parts just to be on the safe side. Using simulation tools, engineers/chief designers can quickly establish the appropriate factor of safety, verify that a design will perform safely in its operating environment, and end the practice of over-designing.

### **Controlling Costs via Reduced Prototyping/Testing**

Engineers/chief designers are not only being tasked with creating better-performing system-level and large-assembly designs in less time, but also to trim costs out of both their designs and development processes. Reducing weight/volume to cut material usage, using a less costly material, or employing a more affordable production technique are all potential cost-savers, and engineers/chief designers can verify that these cost-reducing options will work without resorting to physical prototyping, which increases costs. With simulation tools, engineers/chief designers can quickly explore the various options for reducing costs and learn whether they will satisfy their design criteria.

### **Balancing Performance and Aesthetics**

In addition to demanding that system-level and large-assembly designs perform as intended, most manufacturers want to improve design aesthetics—the look, feel, and general appearance of a product. Maintaining design performance while improving design aesthetics can be tricky, unless engineers and chief designers have a means for determining how design modifications made to enhance design aesthetics impinge upon product performance. A better-looking product design that fails—or requires rework or late-cycle iterations—cannot be counted as a success. With access to simulation tools, engineers/chief designers can quickly learn how aesthetically pleasing design changes affect product performance.

### **Design for Manufacturability**

Affirming the manufacturability of a product design is becoming just as important as validating design performance. With the frequent introduction of new production technologies such as additive manufacturing, engineers/chief designers must continually check to see if there is a better method for producing a part or family of parts or decide to continue to manufacture parts the way they've always been produced. Using CAD-integrated simulation tools, engineers/chief designers can evaluate design geometries against the requirements of different manufacturing techniques, such as machining, injection molding, casting, etc., resulting in better production choices and outcomes.

### **Supporting Concurrent Design**

As many manufacturers adopt a more automated, concurrent approach to product development, the extended product development and manufacturing organization looks to engineers and chief designers to deliver higher-fidelity design data early in the process to support related workflows. With concurrent design, every function connected to design and manufacturing—including visualization, prototyping, validation, cost estimating, manufacturing planning, data management, quality control, documentation, packaging development, and marketing—is able to work with the master product model earlier in the process. Using simulation tools, engineers/chief designers can make sure that a design is finalized earlier in the process, enabling other functions to work with the data sooner, shortening the entire design-through-manufacturing process.

### **Integrated Simulation Accelerates Productization of Design Concepts**

While engineers and chief designers typically have a general understanding of the behavior, performance characteristics, and manufacturability of their system-level and large-assembly designs, they often learn things through prototyping—both product and tooling—that lead to late-cycle design changes. By adding CAD-integrated simulation capabilities to their toolbox, engineers and chief designers can discover performance and manufacturability issues early in the process—prior to prototyping—helping them accelerate the productization of design concepts.

### **Establishing Specifications for Design Team**

Using simulation capabilities, engineers and chief designers can create system-level and large-assembly sketches, and quickly run simulations on them to establish more accurate boundary conditions and specifications for individual part or assembly designs, which the various members of the design team will reference in completing their work. Because these quick-simulated boundary conditions are generally more accurate for a specific case than historical or recorded data, the design team's efforts will better fit the specific case at hand and be less likely to require late-cycle changes or iterations.

### **Refining Innovative Ideas and Concepts**

Accelerating the refinement of innovative ideas or concepts is best achieved using simulation tools. Because refining a design is an iterative process that is most efficient and less costly when performed during initial design, engineers and chief designers can leverage integrated simulation software and share their findings with members of the design team, who can apply the import of this design performance information to their designs. With the ability to perform design-and-simulation iterations quickly, engineers and chief designers can help design team members assess and refine innovative designs early in the process and avoid the time and expense of having to make design refinements later.

### **Making Sure That Safe Is Not Too Safe**

Instead of over-designing parts in areas where a designer thinks they might fail, engineers and chief designers can use CAD-integrated simulation tools to apply the appropriate factor of safety to a design and then validate the design's safety. While all manufacturers want to ensure the safety of their products, they also want to avoid an "overkill" situation in which more material than necessary is used to beef up an area of a design unnecessarily. Using simulation, engineers/chief designers can ensure safety and reduce material usage at the same time.

### **Improving Performance**

By using simulation tools early in the development process, engineers and chief designers not only can ensure that they consistently deliver designs of greater fidelity but can also leverage analysis to actually improve design performance. Having the simulation capabilities embedded directly inside the CAD modeling environment is critically important for doing this efficiently because there's no need to convert or translate files. If an engineer or chief designer has to leave his or her CAD system and export a design into another application to run an analysis, it will take longer and designers won't have the benefit of directly referencing the simulation results while working on a design.

### **Assessing Material Options**

Evaluating material options for a design in the interest of using a less expensive material used to require the documentation of material properties, engineering equations, and a lot of calculations. CAD-integrated simulation tools allow engineers and chief designers to more easily and quickly determine the impact of using alternative materials on design performance. There's an ongoing trend in manufacturing to use a less costly material when doing so doesn't negatively impact performance, such as making metal parts with more affordable plastic. With integrated simulation tools, engineers/chief designers can evaluate different metals, alloys, plastics, and even 3D-printed materials to better understand available material options.

**"With SOLIDWORKS Simulation Professional, I was able to quickly study stress concentrations and deflection of the leaf spring, which operates the trigger mechanism. This enabled me to winnow 30 different designs to three or four for prototyping, and then reduce the number of prototyping cycles required to identify the optimal design."**

— Jeff Davies, Principal Engineer, CamelBak Products LLC

## Evaluating Production Alternatives

What's the best production method for producing a particular part or family of parts? Just as engineers/designers can use simulation tools to assess the use of alternative materials in a design, they can use the same integrated analysis tools to evaluate the manufacturability of a design, so as to choose the most suitable production method. Does the part have enough draft for injection molding? Can it be machined, or will you need to use metal additive manufacturing to produce the part? Is there a better way to make it? Assessing the manufacturability of a design is just as important as validating design performance when trying to avoid late-cycle iterations.

## Concurrent Product Development

More and more manufacturers are adopting an automated, concurrent approach to product development. In this paradigm, creating high-fidelity designs early in the process is imperative because the master design data supports many related downstream functions, such as visualization, prototyping, validation, cost estimating, manufacturing planning, data management, quality control, documentation, packaging development, and marketing. Integrated simulation software can help engineers and chief designers ensure that more complete designs are finished earlier, so downstream functions can begin working with the data sooner and further compress the design-to-manufacturing process.



### a case in point

Ever since founder Michael Eidson filled an IV bag with water, stuck it in a tube sock, and strapped it on his back to compete in the Hotter 'n Hell 100 bike race in Texas in 1988, CamelBak Products LLC has innovated unique ways to stay hydrated. Today, CamelBak is the leading hydration brand, expanding its initial offering of reservoir-backpacks with product lines for the bottled, filtration, and military markets. The company's Hard Goods Group, which focuses on the development of reusable bottles and containers for water and beverages, has made displacing disposable plastic water bottles its ongoing mission.

CamelBak implemented SOLIDWORKS Premium design and SOLIDWORKS Simulation Professional analysis software to support its product expansion, and added SOLIDWORKS PDM Professional product data management software to more efficiently handle the increasing volume of design, engineering, and manufacturing data associated with its products.

"With SOLIDWORKS, we can roll out product innovations in a timely manner," Principal Engineer Jeff Davies says. "We introduced the first BPA-free bottle [BPA is bisphenol A, a harmful industrial chemical] in 2011 and secured a patent for the unique trigger mechanism of our Forge insulated travel mug. SOLIDWORKS helps us to consistently achieve our product development, testing, innovation, ergonomics, and durability goals.

"The Forge travel mug presented an interesting design challenge because we were introducing an industry innovation while attempting to shorten time-to-market," Davies notes. "With SOLIDWORKS Simulation Professional, I was able to quickly study stress concentrations and deflection of the leaf spring which operates the trigger mechanism. This enabled me to winnow 30 different designs to three or four for prototyping, and then reduce the number of prototyping cycles required to identify the optimal design. SOLIDWORKS saves us time and money because we can iterate quickly on a design, helping us to shorten time-to-market, meet firm deadlines, and ensure product durability and performance."

**To read the full CamelBak Case Study, [click here.](#)**



## WHAT TYPES OF SIMULATION TOOLS DO ENGINEERS/CHIEF DESIGNERS NEED?

While simulation tools clearly provide a range of benefits related to the challenges that engineers and chief designers now face, the types of analyses that these individuals need to perform and the capabilities of the simulation tools that will help them do their jobs differ greatly from the traditional finite element analysis (FEA) systems used by analysts. Because engineers and chief designers work and collaborate with designers and design teams, their simulation tools must be integrated directly inside the designer's 3D modeling environment. Similarly, because engineers and chief designers most frequently head up large-assembly and system-level design projects, they need the ability to run simulations at both the component and assembly levels.

### Large-Assembly/System-Level Design Simulations

Managing a design effort whereby individual designers develop different components in an assembly, or a complete assembly or subassembly in system-level designs, requires the ability to be able to run both component- and assembly-level simulations. Engineers and chief designers need assembly analysis capabilities—in addition to individual part analysis—so they can evaluate how component designs work together in an assembly or mechanism, as well as to identify the loads and boundary conditions from which design specifications are drawn.

### Motion/Kinematics

Although not all mechanical assemblies or system-level designs move, many do. These motions and movements can create additional loads on both the assembly and its individual parts. Engineers and chief designers can use kinematics and motion simulation tools to observe how an assembly or system will move, as well as to generate important dynamic loading information for every part in the design. By simulating assembly movement, engineers/chief designers can quickly gain a better appreciation for the dynamics of the entire assembly, accurately establish the load and boundary condition information included with individual part design specifications, and easily locate areas with potential interference and/or clearance issues.

### Stress/Displacement

Structural analysis tools can help engineers and chief designers identify areas of high stress which could result in component failure, in both part and assembly designs as well as predict whether a design will deflect or be displaced, and by how much. By simulating a design's response to the loads and boundary conditions of its operating environment, engineers/chief designers can pinpoint areas of high stress and then use simulation tools to rework the design to bring stresses within allowable levels, verify the appropriate factor of safety, reduce weight/material usage, or validate attempts at miniaturization. Moreover, the same CAD-integrated simulation capabilities will help engineers/chief designers understand whether a design is stiff enough or too stiff to fit a specific function.

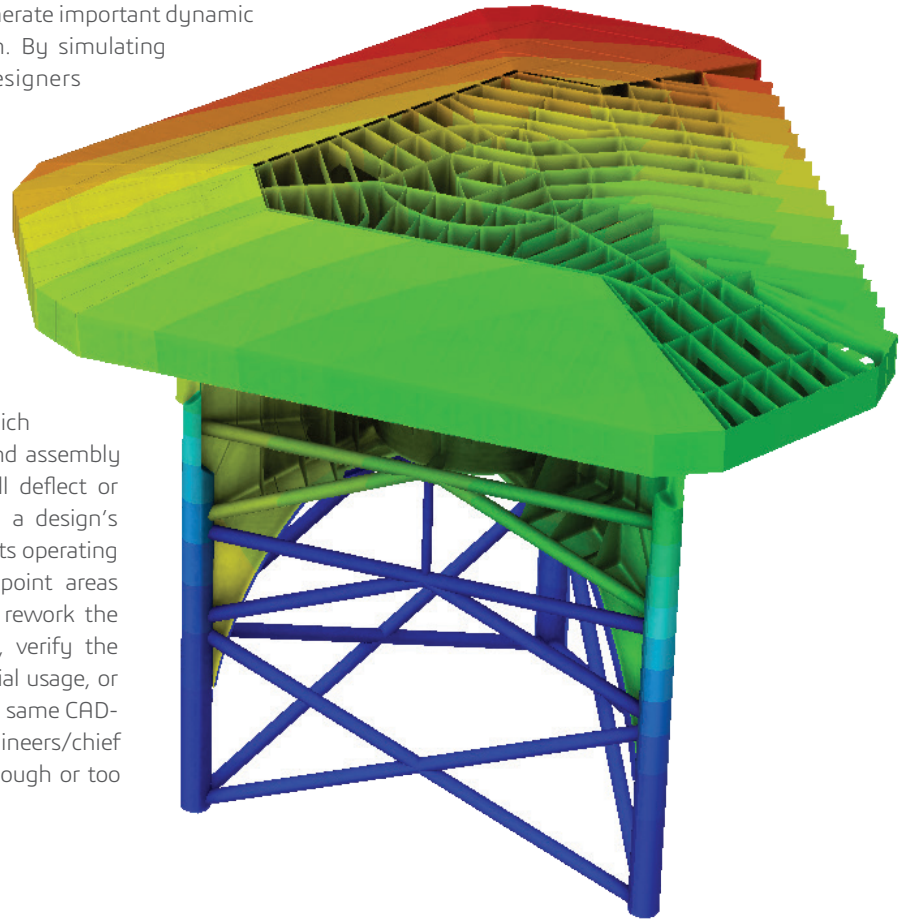

## Thermal Analysis

What are the effects of temperature on a design? Does the heat sink or cooling system carry away enough heat? How can I transfer more heat out of this design? These are the questions that engineers and chief designers can find answers to using thermal analysis software. Understanding the impact of heat transfer effects on an assembly or system and evaluating the efficiency of cooling system designs are critical requirements for delivering high-fidelity system-level and large-assembly designs.

## Frequency Simulations

When dealing with a large-assembly or system-level design, engineers and chief designers certainly want to know whether the design will deflect or be displaced under its operating load. Just as importantly, they'll want to know the natural and resonant frequencies of a design and whether vibration is a concern. By conducting frequency simulations, engineers and chief designers will learn much more than whether a design will deflect and be able to predict if vibration will potentially become an issue. They can then modify the design accordingly to eliminate or dampen vibration.

## Buckling Simulations

While some structures will break under stress, others will buckle, bend, or deform. Through buckling studies, engineers and chief designers can predict the specific failure mode of a design in response to compressive stresses, which can then be used to modify the design to eliminate the likelihood of buckling. Because a buckled/deformed part can create additional loads on other parts of an assembly, it's important for engineers and chief designers to use integrated simulation capabilities to identify and rectify any parts that are likely to buckle.

## Pressure Vessel Simulations

Pressure vessels are designed to contain a variety of liquids, gases, or liquified gases at high pressure. Companies that manufacture pressure vessels are continuously working to optimize pressure vessel designs in terms of wall thickness and material, an effort that is greatly aided through the use of simulation software. In addition to validating that a pressure-vessel design can handle the loads associated with its pressure rating, pressure-vessel simulations can help engineers and chief designers iron out manufacturing or assembly peculiarities.

## Fatigue Simulations

When—after how many cycles—will my large-assembly or system-level design wear out? This is an important question to answer because improving the quality of a product by extending its lifespan—or ensuring that the product will continue to perform past its warranty period—requires an understanding of when the part will wear out. With integrated fatigue analysis tools, engineers and chief designers can predict the number of cycles, or use over time, before a specific component or assembly will fail. They can then use this information to determine whether design changes can extend the life of a part or assembly.

## Drop Test Simulations

What happens if a customer drops my product? In an age of increasingly smaller electronic gadgets, drop test simulations have become vitally important in accelerating product time to market because they eliminate or minimize the need to drop prototypes over and over. And drop tests don't only apply to hand-held products. Many manufacturers of replacement parts also want to know what happens to the part if someone drops it before having a chance to install it. With CAD-integrated simulation tools, engineers and chief designers can quickly run drop test simulations when warranted, helping to keep prototyping to a minimum.

**“We’re still required to test everything, but SOLIDWORKS simulation tools help us to reduce testing cycles and mitigate risk. We also use SOLIDWORKS Simulation Professional software to conduct fatigue and drop test studies, and design testing apparatus with SOLIDWORKS.”**

— Mark Morreale, Mechanical Engineer, Synaptive Medical Inc.



## Topology Optimization—Is There a Better Shape?

Another type of simulation application that is particularly useful in helping engineers and chief designers improve design fidelity early in the process is topology optimization. A topology study uses the maximum allowed design space for a part in combination with applied loads and manufacturing constraints to automatically generate the minimum-mass, optimal shape or geometry for a part. Topology optimization capabilities provide engineers and chief designers with a valuable tool for generating innovative design concepts, establishing starting points for the design team, or generating ideas for refining an existing design.

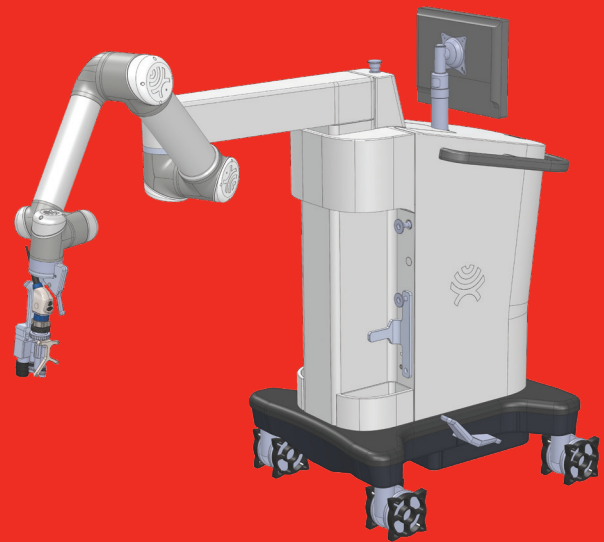

### a case in point

In only four years, Synaptive Medical Inc. has introduced a range of products and systems that help neurosurgeons operate more precisely and effectively, introducing technology that could potentially lead to improved outcomes for brain surgery patients. With a talented team of scientists, engineers, business leaders, and customer care specialists, the Toronto-based medical device and technology company strives to ensure the best possible patient outcomes, inspiring the innovations and advancements that the complex discipline of neurosurgery demands.

When the founders launched Synaptive Medical in 2012, they realized the company would need a 3D product development platform that not only provided extensive, integrated capabilities, but that also was well established enough to enhance recruitment efforts and support rapid growth. Synaptive Medical chose SOLIDWORKS solutions to support its ambitious product development goals because the software is easy to use, provides a wide range of integrated capabilities, and is the preferred design tool of a large number of designers and engineers. The company implemented SOLIDWORKS Professional design, SOLIDWORKS Premium design and analysis, SOLIDWORKS Simulation Professional analysis, SOLIDWORKS PDM Professional product data management, and SOLIDWORKS Composer technical communication software solutions.

Using integrated SOLIDWORKS solutions, including SOLIDWORKS Simulation Professional analysis software, Synaptive Medical quickly developed and introduced its BrightMatter suite of neurosurgical solutions. "Our BrightMatter Drive product features a cantilevered robotic arm that is suspended over the patient," Morreale explains. "We used SOLIDWORKS Simulation Professional software to ensure that our design satisfied the safety factors for stress and strength required by the IEC (International Electrotechnical Commission) 60601 Standard for all medical electrical equipment.

"We're still required to test everything, but SOLIDWORKS simulation tools help us to reduce testing cycles and mitigate risk," Morreale stresses. "We also use SOLIDWORKS Simulation Professional software to conduct fatigue and drop test studies, and design testing apparatus with SOLIDWORKS."

**To read the full Synaptive Medical Case Study, [click here.](#)**

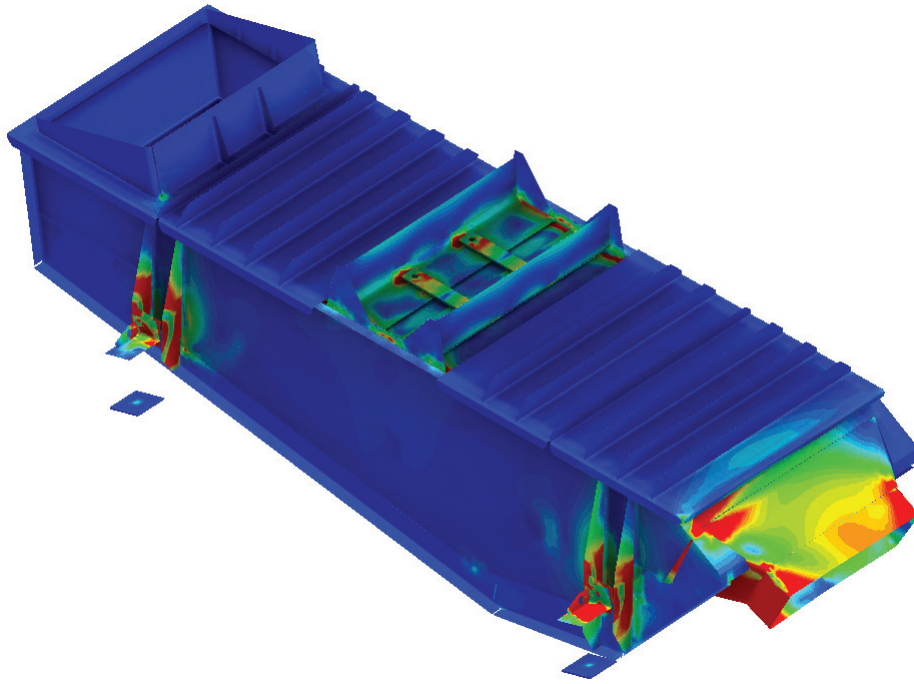

## **QUICKLY REAP THE BENEFITS OF SIMULATION-DRIVEN PRODUCT DEVELOPMENT WITH SOLIDWORKS SIMULATION PROFESSIONAL**

As engineers and chief designers, you can reap the benefits of simulation-driven design and ease the implementation of powerful simulation capabilities by adding integrated SOLIDWORKS Simulation Professional software to your SOLIDWORKS CAD system. Switching to SOLIDWORKS as your 3D development system and incorporating SOLIDWORKS Simulation Professional software will give you access to the analysis tools that engineers and chief designers use most from inside your modeling environment.

### **Open a Window into Design Behavior to Manage Large Design Projects More Efficiently and Effectively**

SOLIDWORKS Simulation Professional software opens a window into design behavior by providing engineers and chief designers with an intuitive, virtual testing environment for linear static, time-based motion, thermal, frequency, buckling, pressure-vessel, drop-test, and high-cycle fatigue simulation inside the SOLIDWORKS CAD system. Engineers and chief designers can tackle common system-level and large-assembly engineering challenges with these tools, enabling them to more accurately create design specifications, validate innovative concepts, ensure product safety, control costs, minimize physical prototyping, improve design performance, enhance design aesthetics, verify manufacturability, and support concurrent approaches to product development.

### **Evaluate Performance vs. Design Options**

With CAD-integrated SOLIDWORKS Simulation Professional software, engineers and chief designers will be able to quickly compare the performance of a system-level or large-assembly design under load against a range of other design options. What if I use a different material? With SOLIDWORKS Simulation Professional, you can evaluate as many materials as you like. What if I use differently shaped parts? With SOLIDWORKS Simulation Professional, you can assess as many shapes as you like and also generate the optimal shape of each part using topology optimization. What if I use a different production method? With SOLIDWORKS Simulation Professional, you can answer all of these “what ifs” and many more.

### **Minimize Physical Prototyping/Testing Requirements**

SOLIDWORKS Simulation Professional software helps you save your company money by minimizing physical prototyping and testing requirements. Because engineers and chief designers can virtually prototype and test a design in software, they will only need to prototype a design when required by regulatory or safety requirements or for final validation. All other testing can be done with SOLIDWORKS Simulation Professional, a process which will shave time out of the development cycle, control prototyping costs, and produce better-performing products.

### Reduce Weight and Material Usage

Cutting the weight of a design, and thereby reducing material usage, is the most obvious cost-saving approach available to engineers and chief designers. Reducing weight is also an important design requirement in some industries, including automotive and aerospace. With SOLIDWORKS Simulation Professional software, engineers and chief designers can validate trimmed down designs to make sure that they still meet performance requirements, as well as run design optimization loops, using weight as the optimization variable, to fully optimize a design based on weight.

### Optimize Parts when Necessary

Per the weight example in the previous section, SOLIDWORKS Simulation Professional software provides engineers and chief designers with the ability to optimize a design based on a user-defined variable or objective. If you want to optimize the design to uncover the lightest shape that will still bear a specific load, you would optimize on weight. But you can also optimize designs based on other variables, such as thickness, temperature, volume, etc. These design optimization capabilities give engineers and chief designers the power to optimize any part in any way they see fit, when necessary.

### Streamline System-Level/Large Assembly Design, Improve Performance with SOLIDWORKS Simulation Professional Virtual Testing Tools

With the virtual testing tools provided by SOLIDWORKS Simulation Professional software, you can get fast, accurate answers to important questions about the behavior, performance, and manufacturability of your system-level and large-assembly designs without the expense of physical testing. By learning more about the performance and manufacturability aspects of component and assembly designs, you'll be able to more consistently produce high-fidelity designs early in the product development process. With SOLIDWORKS Simulation Professional solutions, you can get reliable answers to the following performance questions about your system-level and large-assembly designs:

- Will the product break, and if so, where?
- Where can we remove material and where do we need to add it to improve performance?
- Can we use a less expensive material or production technique and still achieve the desired performance?
- Does the design have the required factor of safety?
- Is the design stiff enough or too stiff?
- Where can we add material to address deflection/displacement?
- Will a design's loads cause it to reach one of its natural frequencies and induce vibrations?
- How can we alter the design to dampen vibration?
- When (after how many cycles) will a design wear out?
- How will a system design or large assembly move?
- Will a system design or large assembly break, buckle, bend, or deform?
- How can we alter the design to ensure that it won't break, buckle, bend, or deform?
- How will thermal effects impact design performance?
- Is a cooling system design efficient enough?
- Is a pressure vessel design optimized?
- Will the movements of my assembly create loads that cause components to fail? If so, which components and how can I improve performance?
- Am I working with the best shape or is there another that performs better?
- Am I ready to move to manufacturing?
- What's the best method to produce a design?

**“The vertical storage racking systems that we developed for Big Steel Rack needed to hold a lot of weight without bending or deflecting. We added SOLIDWORKS Simulation Professional structural analysis software to determine and evaluate the load limitations—in terms of stress and deflection—of our vertical racking system designs. This is one of many examples of how SOLIDWORKS tools are helping us to grow the business and extend our range of capabilities.”**

— Ryan McClain, Engineering Manager, Technique, Inc.

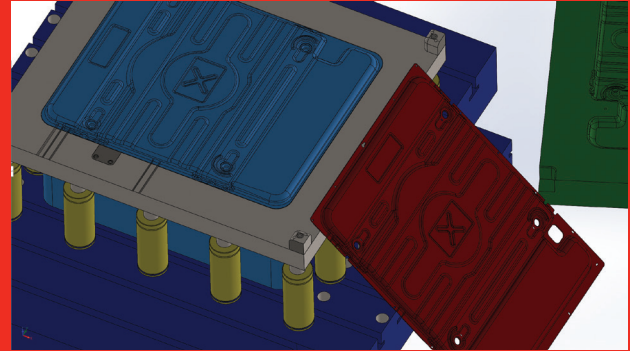
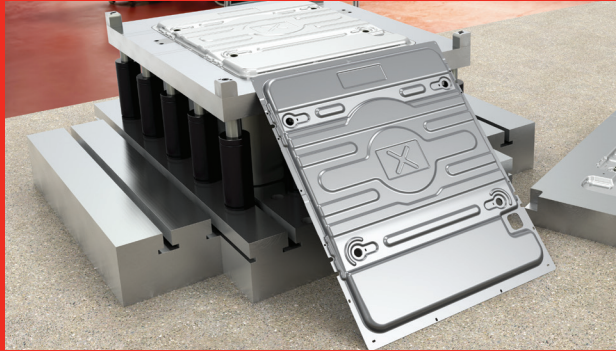

### **a case in point**

Technique, Inc. is a prototype metal stamping, tube bending, and low-volume manufacturing company that serves customers worldwide in a variety of industries. Founded in 1991 as a prototype metal stampings business, the company has expanded, and now handles many types of fabricated metals applications in the automotive, heavy truck, agricultural, auto racing, off-highway vehicle, recreational vehicle, household appliance, defense, aerospace, and rail car industries.

Technique decided to transition from AutoCAD® 2D tools, which the company utilized to support its MasterCAM® machining package, to a 3D design system in 2005. The company chose SOLIDWORKS® Standard design software because it's easy to use, compatible with different types of design data, and works well with MasterCAM software. The company then added SOLIDWORKS Inspection software and SOLIDWORKS Simulation Professional structural analysis software solutions to further support achievement of its efficiency and quality objectives, and DraftSight™ 2D drafted software for modifying blanks on the shop floor. "We strive to run our operation as lean and mean as possible, and we determined that SOLIDWORKS was the best 3D package to help us do that," notes Engineering Manager Ryan McClain.

Technique added SOLIDWORKS Simulation Professional structural analysis software to support the development of sheet-metal racking and storage systems for subsidiary company Big Steel Rack. These systems are designed to warehouse and organize sheet metal of various gauges and sizes, and Technique needed structural finite element analysis (FEA) tools to validate the performance of system designs.

"The vertical storage racking systems that we developed for Big Steel Rack needed to hold a lot of weight without bending or deflecting," McClain stresses. "We added SOLIDWORKS Simulation Professional structural analysis software to determine and evaluate the load limitations—in terms of stress and deflection—of our vertical racking system designs. This is one of many examples of how SOLIDWORKS tools are helping us to grow the business and extend our range of capabilities."

**To read the full Technique Case Study, [click here](#).**

## IMPROVE SYSTEM-LEVEL DESIGN, MANUFACTURING PLANNING, AND PRODUCT QUALITY WITH SOLIDWORKS SIMULATION PROFESSIONAL-DRIVEN PRODUCT DEVELOPMENT

Competing successfully in today's global market requires manufacturers to increase innovation, automation, and throughput. These objectives trickle down to engineers and chief designers in the form of greater demands to deliver more complete system-level and large-assembly designs early in the product development process. By generating higher-fidelity designs that minimize or eliminate design behavior and/or manufacturability issues late in the product development process, engineers and chief designers can help shorten design cycles, minimize prototyping, streamline the transition to manufacturing, and deliver innovative, better-performing products.

Developing successful products requires everyone associated with product development to do more—including engineers and chief designers—by working smarter to support changing product development requirements. As engineers and chief designers, you can meet the challenge of creating higher-fidelity system-level and large-assembly designs earlier in the process by adding SOLIDWORKS Simulation Professional software to your SOLIDWORKS 3D design installation. Using the powerful combination of intuitive SOLIDWORKS modeling capabilities and integrated, easy-to-use SOLIDWORKS Simulation Professional design analysis tools, you can consistently create higher-fidelity system-level and large assembly designs, which will help your company spend less time resolving product performance or manufacturability issues late in the process; minimize the frequency of rework and retrofits to address problems; and eliminate costly field failures, returns, and warranty claims.

To learn more about how SOLIDWORKS Simulation Professional software can improve the fidelity of your system-level and large-assembly designs, visit [www.solidworks.com](http://www.solidworks.com) or call 1 800 693 9000 or 1 781 810 5011.

---

### Our 3DEXPERIENCE® platform powers our brand applications, serving 12 industries, and provides a rich portfolio of industry solution experiences.

Dassault Systèmes, the 3DEXPERIENCE® Company, provides business and people with virtual universes to imagine sustainable innovations. Its world-leading solutions transform the way products are designed, produced, and supported. Dassault Systèmes' collaborative solutions foster social innovation, expanding possibilities for the virtual world to improve the real world. The group brings value to over 220,000 customers of all sizes in all industries in more than 140 countries. For more information, visit [www.3ds.com](http://www.3ds.com).



### SIM Technologies Pvt. Ltd.

3rd Floor, "Mamanjee Centre",  
S7-A, Thiru-Vi-Ka Industrial Estate,  
Guindy, Chennai – 600 032

+91-8754447021

marketing@simtek.in