



GOING BEYOND DESIGN: MAKING CAD THE CORNERSTONE OF AN INTEGRATED-DESIGN-TO- MANUFACTURING PROCESS

White Paper

OVERVIEW

Integrated 3D computer-aided design (CAD) technologies increasingly hold the key to optimizing the entire design-to-manufacturing process, enabling manufacturers to bring better products to market faster than the competition. Although CAD has historically focused on design modeling, with manufacturing drawings being the final product, CAD data can now be used to streamline and automate other important downstream tasks.

These tasks include virtual product simulation and design validation, reducing the need for physical prototypes; CAM (computer-aided manufacturing) programming, generating tool paths for CNC machining; additive manufacturing processes, including metal and plastics; mold, tool, die, and fixture development, supporting manufacturing processes; cost estimation and quoting, automating aspects of purchasing; shop floor documentation creation, including drawings, BOMs (bills of materials), assembly instructions, and exploded views; quality control inspection, formalizing inspection of incoming and manufactured parts; documentation development, automating the creation of user manuals and service guides; and photorealistic rendering, streamlining the development of high-quality images, videos, and interactive web content.

What's more, integrated CAD can support these functions in a concurrent rather than a serial fashion. By helping manufacturers eliminate redundancies, unnecessary effort, and the potential for error, integrated SOLIDWORKS® Premium 3D design software can serve as the cornerstone of an integrated design-to-manufacturing process, providing the efficiency, agility, and flexibility that manufacturers need to maintain a competitive edge.

EXECUTING DESIGN AND MANUFACTURING SEPARATELY INHIBITS COMPETITIVENESS

The traditional design-to-manufacturing process, whereby designers and engineers design products and create drawings, and manufacturing professionals use those drawings to produce and assemble products through separate, serial, nonintegrated processes, is gradually becoming obsolete. Demands for product innovation, improved quality, and faster time-to-market require increased efficiency and greater automation in the entire design-to-manufacturing process.

Historically, not only were design and manufacturing functions conducted separately—one after the other—different aspects of product design were as well. Typically, companies completed mechanical, electrical, and electronic design sequentially, using different design tools, so it made sense to wait until all design work was complete before initiating production. However, in a fast-paced, global market, manufacturers no longer have the luxury of developing and manufacturing products one step at a time.

In today's highly competitive environment, manufacturers can't afford to approach design and manufacturing separately, with little interaction or collaboration between design and production, except when errors or issues arise. That's because the frequency of engineering change orders (ECOs), retrofits, and rework with a nonintegrated, sequential approach to design and manufacturing is much higher, adding time and cost to your bottom line.

Another disadvantage of the conventional, sequential approach to design and manufacturing is its reliance on two separate data streams: CAD for design and CAM for machining. Product geometry data is the language of design and manufacturing. Having separate CAD and CAM data formats inhibits communication and stifles collaboration, negatively affecting quality, just like speaking two different languages would.



Learn how **SOLIDWORKS CAM's** tolerance-based machining helps Ringbrothers quickly create new parts for their line of high-quality billet accessories and custom car business.

The advantages of an integrated, design-to-manufacturing process all relate to bringing better products to market faster and at lower cost through greater collaboration and automation, thereby boosting your company's competitiveness. With integrated 3D CAD data driving every function from concept through production, your organization will save time, control costs, increase accuracy, improve communication, foster innovation, and enhance design for manufacturability.

The cornerstone of a building joins two walls at their base. Integrated CAD technologies like SOLIDWORKS Premium design software, through which 3D design data drives and automates the entire design-to-manufacturing process concurrently, can similarly bridge the gap between design and manufacturing, and provide the productivity gains that today's manufacturers need to compete successfully.



...a case in point

Automatic Handling International, Inc. is a worldwide manufacturer of custom handling and packaging systems, serving leading companies in the pulp and paper, tissue and towel, nonwovens, fiberglass, agriculture, stone, and steel industries. The company transitioned from AutoCAD® 2D development tools to the SOLIDWORKS Professional 3D design platform, choosing SOLIDWORKS for its ease of use, large assembly capabilities, and extended suite of integrated solutions.

Automatic Handling then implemented SOLIDWORKS Premium design and analysis software to take advantage of integrated finite element analysis (FEA) tools, SOLIDWORKS PDM Professional product data management (PDM) software to automate workflows and revision controls, and SOLIDWORKS Composer™ technical communication software to accelerate the development and improve the quality of machine assembly and usage documentation.

While the company realized time and cost savings by moving from 2D to 3D, the ability to access the open SOLIDWORKS Application Programming Interface (API) enabled Automatic Handling to further automate workflows and processes, achieving natural synergies and resulting in a completely paperless, more efficient, model-based definition (MBD) approach to production. "Using the SOLIDWORKS API, we've leveraged SOLIDWORKS PDM Professional to combine SOLIDWORKS eDrawings® files with manufacturing and production information instructions through computer terminals in the shop—completely eliminating paper drawings, travelers, etc.," explains Mechanical Engineer Phil Morris.

By selecting SOLIDWORKS solutions and working with the open SOLIDWORKS API, Automatic Handling has cut manufacturing release times by 80 percent; replaced paper drawings with digital 3D models for production; empowered machinists and fabricators as part of the development process; and eliminated printing, paper, and administrative costs.

Read the full story here:
[Automatic Handling International Case Study.](#)

LIMITATIONS OF SEPARATE, NONINTEGRATED DESIGN-TO-MANUFACTURING PROCESSES

Even though the sequential, nonintegrated approach to the design-to-manufacturing process has worked well in the past for many manufacturers, it carries a plethora of limitations when compared to an integrated, automated approach. Some of these restrictions are fairly obvious, while others are quickly revealed when companies seek to automate their product development and production processes.

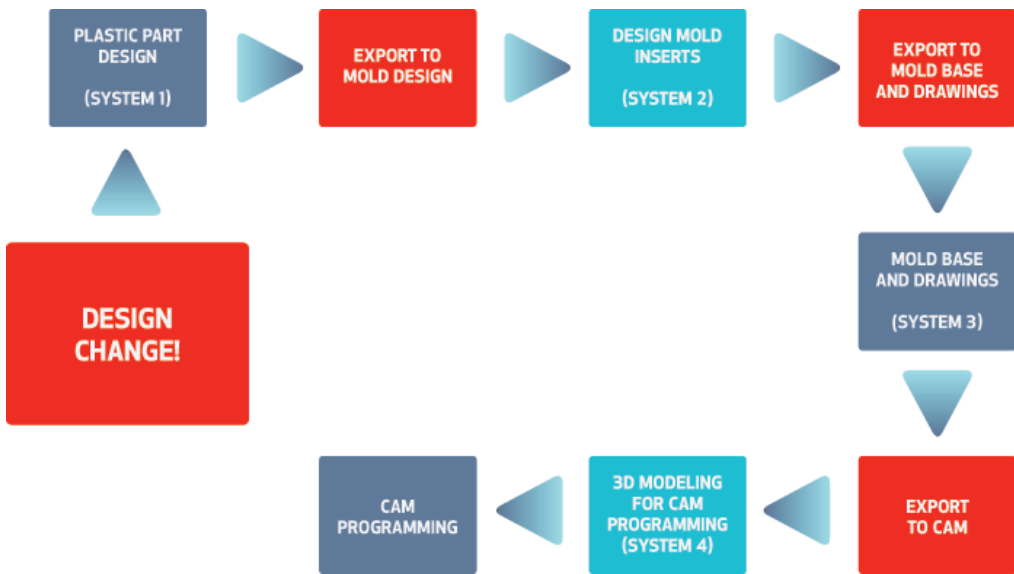

The nonintegrated approach to design-to-manufacturing adds unnecessary time and costs related to communication barriers and iterations late in the process.

Design Takes Longer

When organizations develop and manufacture products sequentially instead of concurrently, and separately rather than collaboratively, the process inherently takes longer. Every function from concept development to final production—including visualization, communication, validation and prototyping, cost estimating, G code development for machining, inspection, assembly, documentation, and data management—generally is performed separately from design with nonintegrated tools. This approach requires file transfers and data conversions, often resulting in unnecessary, duplicative work that adds time and costs to the process.

Handoff to Manufacturing Fumbles

When paper 2D drawings are the vehicle for the handoff to manufacturing instead of integrated 3D data, the transition is often anything but smooth. By their very nature, 2D drawings are difficult to read, extrapolate, and manage. Creating G code for machining and developing tooling with nonintegrated data adds time to the process. But perhaps most importantly, assessment of a design’s manufacturability—gaining an understanding about whether a design can cost-effectively be manufactured at volume at a profit using available production techniques—is often done after the fact. This leads to design iterations late in the process that could have been done earlier, when they are less costly.

Increased Number of ECOs, Manufacturing Rework

Without the input and collaboration of manufacturing experts during initial product design, manufacturers will most likely experience a greater number of ECOs and manufacturing rework, and their attendant costs and delays, than they would have with an integrated design-to-manufacturing platform. Furthermore, it will take longer to execute ECOs when the design data and machining and production data reside in different data formats, and the likelihood of errors creeping into the process will increase.

Reluctance to Make Late-Process Changes

With a lack of integration between design and manufacturing data comes an organizational reluctance to make design changes late in the process because the time and cost burdens associated with such changes are viewed as prohibitive. With an integrated design-to-manufacturing environment, through which late-process design changes can be made quickly, easily, and cost-effectively, such changes are no longer a big deal, enabling manufacturers to make quality improvements whenever they are needed.

Completing Functions Separately Costs More, Lengthens Time-to-Market

Because accelerating time-to-market is so vital to a product's success, and impinges on a manufacturer's overall performance, completing as many functions as possible simultaneously and collaboratively has become a critically important strategic objective. With a nonintegrated design-to-manufacturing platform, every step in the process has to be done separately, which incurs unnecessary costs in addition to lengthening product time-to-market. With an integrated system, through which all changes related to separate functions propagate to the 3D model data at the center of the design-to-manufacturing universe, completing functions simultaneously is more than possible: It's fast, easy, and collaborative.



...a case in point

While Brudden Equipment Ltd. is known throughout South America as the manufacturer of the Brudden® brand of agricultural machinery, the company also produces recreational kayaks, as well as the market-leading Movement® brand of physical fitness equipment. With the largest market share in the South American fitness equipment market, Movement products cater to all sizes of gyms, studios, condos, clubs, hotels, clinics, and personal residences.

According to Engineering Manager Victor E. F. Xavier, the company's growth and product expansion led to a re-evaluation in 2007 of the Mechanical Desktop® and Autodesk® Inventor® design tools it used as part of Brudden's efforts to shorten product development, improve quality, and reduce time-to-market. "We wanted to streamline and accelerate development—with faster solutions for handling sheet metal, complex geometries requiring surfacing, and integrated design analysis—to support our product line expansion and need for greater throughput," Xavier explains.

After evaluating the Pro/ENGINEER® and SOLIDWORKS 3D design systems, Brudden standardized on SOLIDWORKS solutions, implementing SOLIDWORKS Standard design, SOLIDWORKS Professional design, SOLIDWORKS Premium design and analysis, SOLIDWORKS Simulation Premium analysis, and SOLIDWORKS Composer technical communication software. "We chose SOLIDWORKS because it had the shortest learning curve, was competitively priced, and provided access to integrated engineering tools," Xavier recounts. "SOLIDWORKS was simply the best solution for introducing 3D design across Brudden."

By moving to SOLIDWORKS, Brudden shortened product time-to-market by 25 to 30 percent, cut prototyping costs by 40 percent, quadrupled annual new product development throughput, and won the 2015 International iF Design Award.

Read the full story here: [Brudden/Movement Case Study](#).

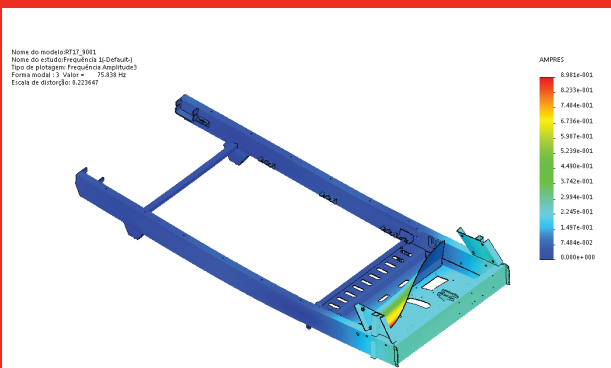

ADVANTAGES OF INTEGRATED CAD AS CORNERSTONE OF CONCURRENT DESIGN-TO-MANUFACTURING PROCESS

When 3D CAD data resides at the center of the design-to-manufacturing process, product development and manufacturing organizations reap a host of productivity improvements across every related function. By eliminating the limitations of the sequential, nonintegrated approach to design and manufacturing and supporting a range of additional automation-driven benefits, integrated CAD can help you revitalize your product development and manufacturing operations and help you achieve your product, manufacturing, and business goals.

Shorter Design Cycles, Time-to-Market

With an integrated CAD design-to-manufacturing system, you will be able to shorten design cycles and accelerate time-to-market because design changes will automatically update across all downstream functions. In other words, when the 3D CAD model, the cornerstone of the process, is changed, that change automatically ripples across all other downstream data—from photorealistic renderings, simulations and prototypes, and cost estimates to CAM programming, documentation development, and data and revision management. With an integrated, concurrent, and collaborative approach, none of the downstream changes need to be executed manually. It's automatic.

Manufacturing Involved Early in Process

When integrated CAD drives both design and manufacturing, production professionals get involved earlier in the development process. Instead of waiting for the release of 2D paper drawings, manufacturing personnel will be able to evaluate and provide input on the manufacturability of a design, develop CAM programming (G code), and create tooling far sooner in the process. More importantly, any subsequent design changes will automatically update manufacturing systems. Integrated CAD is also a must for taking advantage of MBD (model-based definition) technology, which replaces paper 2D drawings with onscreen 3D CAD models and dimensional information to support production.

See how integrated SOLIDWORKS CAD/CAM is making a big difference at .decimal in the fight against cancer.

Fewer ECOs, Faster and Easier to Execute

Greater collaboration among designers and manufacturing specialists early in the development process typically results in fewer ECOs, and the ECOs that are generated are faster and easier to execute. Because product developers and production personnel engage sooner and speak the same language (rely on the same geometry data and integrated tools), they can pinpoint and rectify potential design or production problems that formerly would have resulted in the issuance of an ECO, effectively reducing the number of ECOs. And if they fail to catch something that does require an ECO, they can make the change quickly and easily because their systems will update to incorporate the change necessitated by the ECO.

Late-Process Design Changes No Longer Time- and Cost-Prohibitive

By employing an integrated CAD approach to design and manufacturing, your engineering and manufacturing departments will become much more agile and flexible, enabling them to make changes very late in the process that may improve a product's performance, increase customer satisfaction, and lead to the product's success in the market. Late-process design changes will no longer be something to be feared or avoided, due to the voluminous amount of busy work they once heralded. Instead, because late-process changes are fast and easy, updating all associated systems, they will become viewed as opportunities to improve a product or manufacturing process, leading to higher quality overall.



...a case in point

Taking its name from the popular Dutch drop licorice candy and 3D (ddd), dddrop 3D Printers has introduced new 3D printing systems specifically designed to satisfy the needs of engineers at an affordable price. “Rather than imagining the printing functionality and features that our customers need, we decided to quickly develop and deploy the Recon 3D printer as a way to survey our customer base,” dddrop owner and CEO Alfred Uytdewilligen explains.

The company funneled its customers’ insights into the development of the dddrop Leader single-head 3D printer—introduced in 2015—and the dddrop Leader TWIN dual-head 3D printer—launched in 2016. dddrop chose the integrated SOLIDWORKS design-to-manufacturing ecosystem, including SOLIDWORKS Premium mechanical design, SOLIDWORKS Electrical Schematics design, SOLIDWORKS PCB electronic design, SOLIDWORKS Simulation Premium structural analysis, SOLIDWORKS Flow Simulation Electronics Cooling Module thermal analysis, SOLIDWORKS PDM Professional product data management, SOLIDWORKS Visualize rendering, and SOLIDWORKS Composer technical communication software solutions, to develop its printers.

“Because we completed development on an integrated platform—with all data managed in SOLIDWORKS PDM—we were able to collaborate and iterate more effectively, avoiding the file transfers, data conversions, and additional work associated with using separate tools,” Uytdewilligen notes. “When changes were made, they rippled across all of the systems. This enabled us to cut the development time for the Leader TWIN in half while reducing prototyping requirements by a factor of three.”

By utilizing the integrated SOLIDWORKS design-to-manufacturing platform, dddrop cut its development cycle in half; reduced the number of prototypes required by a factor of three; tripled printer sales in one year; and completed mechanical, electrical, and PCB design in parallel.

Read the full story here: [ddd 3D Printer Case Study](#).

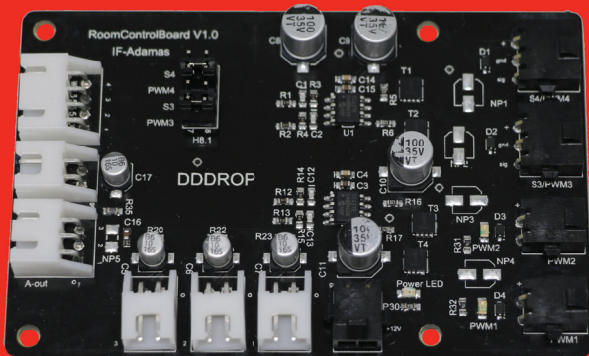

AUTOMATE DEVELOPMENT THROUGH PRODUCTION WITH INTEGRATED SOLIDWORKS PREMIUM DESIGN-TO-MANUFACTURING PROCESS SOLUTIONS

SOLIDWORKS Premium mechanical design software is the cornerstone of the integrated SOLIDWORKS design-to-manufacturing process solution. SOLIDWORKS is well known for its 3D design modeling capabilities, but SOLIDWORKS Premium software also includes a wide range of integrated applications that can help you transform, automate, and improve the way you design and manufacture products. Known as “standard” products and included with SOLIDWORKS Premium software, these capabilities provide benefits at each phase of the development and production process.

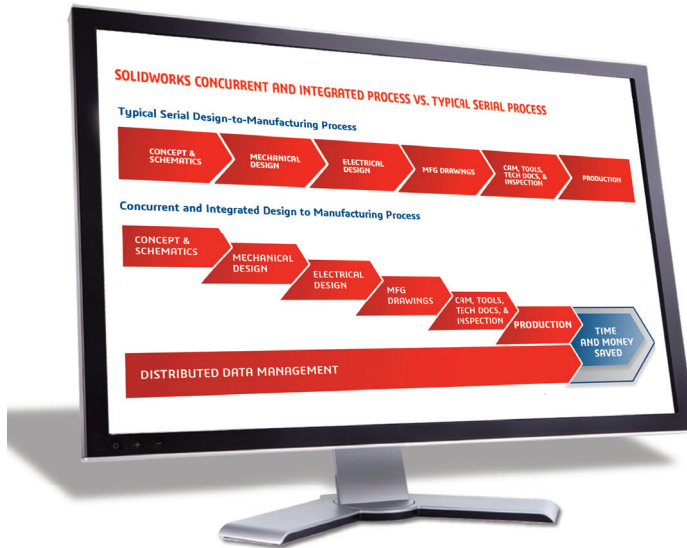

At the center of an integrated solution is a shared 3D CAD model, enabling design or manufacturing changes to be effectively managed and allowed to propagate automatically to all related downstream systems.

Concepts and Schematics

With the robust, easy-to-use sketching capabilities of SOLIDWORKS Premium and the integrated electrical schematics layout tools of SOLIDWORKS Electrical, the development of mechanical design concepts and electrical schematic layouts can occur in an integrated manner and continue while downstream functions are completed concurrently. You can also tap the 3D Interconnect capabilities included with SOLIDWORKS Premium software to import or work on concepts that were created in other CAD design formats.

Mechanical Design

SOLIDWORKS Premium will help you transform concepts and sketches into accurately dimensioned 3D mechanical design models. You can then leverage this cornerstone 3D model data and SOLIDWORKS Premium for a variety of downstream functions, such as conducting linear static stress simulations, completing tolerance stackups with the TolAnalyst™, using SOLIDWORKS Visualize Standard to create photorealistic renderings, employing the Costing module to estimate manufacturing costs, utilizing DFMXpress to assess design for manufacturability, communicating via SOLIDWORKS eDrawings, evaluating the sustainability of a design with SOLIDWORKS Sustainability, or making prototypes on a 3D printer. Any changes that are made to the cornerstone SOLIDWORKS design model automatically update all downstream data functions.

Electrical Design

By adding SOLIDWORKS Electrical 3D design to your SOLIDWORKS Premium installation, you can integrate mechanical and electrical design inside a single 3D environment. This can lead to increased collaboration between mechanical and electrical designers, as well as the improved efficiencies—in estimating, purchasing, and manufacturing preparation and sourcing—associated with generating a single, unified bill of materials (BOM) for all mechanical and electrical components. You can also use SOLIDWORKS Premium to automate the routing of electrical cables, wiring, and harnesses.

Manufacturing Drawings

Detailing manufacturing drawings—as well as updating views due to design changes—is a thing of the past with SOLIDWORKS Premium software, which generates accurate, fully dimensioned manufacturing drawings from the cornerstone 3D model automatically. Just like the other downstream functions, design changes to the model also propagate to any associated drawings, eliminating the unnecessary, time-consuming task of updating different drawing views. And instead of managing paper manufacturing drawings in a cabinet or drawer, you can use SOLIDWORKS PDM Standard product data management software to efficiently manage all design data, including drawings.

CAM, Tool Development, Technical Documentation, and Inspection

With SOLIDWORKS Premium design software, you not only have robust product design tools, but also have access to the tooling development and machining capabilities that you need to integrate and improve your design-to-manufacturing process. SOLIDWORKS CAM Standard software is a fully integrated, Knowledge-Based, 2.5-axis milling and turning solution, which allows you to integrate design and manufacturing processes under one system. Included with SOLIDWORKS Premium, SOLIDWORKS CAM Standard provides a single format and data stream to support design and manufacturing. With SOLIDWORKS Composer and SOLIDWORKS Inspection software, you can leverage the cornerstone SOLIDWORKS 3D model to automate the creation of technical documentation and assembly instructions and the inspection of incoming parts and manufactured pieces, respectively.

CONNECTIONS TO ADDITIONAL CAPABILITIES

SOLIDWORKS Premium is integrated with additional software solutions, including Professional- and Premium-level applications, which provide access to more extensive, robust capabilities. While not included in SOLIDWORKS Premium, these solutions connect to and integrate with SOLIDWORKS Premium software, just like included SOLIDWORKS Standard products.

PCB Electronics Design

Jointly developed by SOLIDWORKS and Altium, SOLIDWORKS PCB powered by Altium software is an electronic and mechanical design solution that allows you to automatically keep your electronic/printed circuit board and mechanical designs synchronized, as well as facilitate change order processing through use of the software's distinct workflows. By providing proven electronic design technology and a streamlined schematics editor within a unified electromechanical design environment, SOLIDWORKS PCB is the integrated development environment for collaborating on and innovating electromechanical products.

Photorealistic Rendering

SOLIDWORKS Visualize Professional software provides advanced photorealistic rendering capabilities over and above those provided with SOLIDWORKS Visualize Standard. With these integrated tools, you can leverage SOLIDWORKS Premium 3D CAD data to create photorealistic marketing content that is print- and web-ready in minutes. From static images to animations and immersive web content, SOLIDWORKS Visualize products deliver photographic content that clearly and emotionally depicts products in the real world.

Product Data Management

SOLIDWORKS PDM Professional and SOLIDWORKS Manage software are full-featured data and project management solutions that extend the capabilities of SOLIDWORKS PDM Standard for organizations large and small. While SOLIDWORKS PDM Standard (included with SOLIDWORKS Premium) is designed to meet the needs of workgroup environments in a single geographic location, SOLIDWORKS PDM Professional and SOLIDWORKS Manage data and project management capabilities are designed to meet the needs of more extensive organizations with more than one location.

Injection-Molded Plastics

SOLIDWORKS Plastics software brings easy-to-use injection-molding simulation directly to the designers of plastic parts and injection molds. The software simulates how melted plastic flows during the injection-molding process to predict manufacturing-related defects on parts and molds. You can quickly evaluate manufacturability while you design, to eliminate costly mold rework, improve part quality, and accelerate time-to-market. SOLIDWORKS Plastics enables you to optimize parts for manufacturability in the early stages of design.



...a case in point

For over 100 years, Dixon Valve & Coupling has manufactured and supplied hose couplings, valves, dry-disconnects, swivels, and other fluid-transfer and control products. The company's global reach—with a dozen manufacturing centers worldwide— includes a broad range of products for the petroleum exploration, refining, transportation, chemical processing, food and beverage, steel, fire protection, construction, mining, and manufacturing industries. With a strategic objective of developing solutions that make its products safer, leak-free, longer lasting, and always available, Dixon established its in-house automation team to automate production where it is justified.

The Dixon automation team relies on SOLIDWORKS 3D design software, which the company has used for 20 years. Since its initial SOLIDWORKS implementation, the manufacturer has acquired additional SOLIDWORKS solutions, including SOLIDWORKS Professional, SOLIDWORKS Premium, SOLIDWORKS Electrical design, SOLIDWORKS Simulation Premium analysis, SOLIDWORKS Flow Simulation, SOLIDWORKS Inspection, SOLIDWORKS Composer, and SOLIDWORKS PDM Standard software solutions. Recently, Dixon added the free Xometry add-in to SOLIDWORKS software to support quoting, feedback, and ordering of manufacturing services from directly within the SOLIDWORKS CAD environment.

"We often ask ourselves: What is the optimal manufacturing solution? What is the best way to make this part? What will it cost?" Industrial Engineer J.R. Everett explains. "With the free Xometry add-in to SOLIDWORKS, we have 24/7 access to production pricing and ordering information inside SOLIDWORKS, and a way to obtain feedback about determining the best way to manufacture a part."

By using SOLIDWORKS and Xometry solutions, Dixon cut fixture production time from weeks to days, determined the cost and suitability of production approaches while designing, reduced fixture production costs, and realized 24/7 access to manufacturing services.

Read the full story here: [Dixon Valve & Coupling Case Study](#).



Manufacturing

Because integrated CAM capabilities are becoming more important for making machining more efficient and manufacturability assessment easier early in the design process, SOLIDWORKS also offers a more robust 2.5-axis milling and turning solution with SOLIDWORKS CAM Professional software. The application extends the capabilities of the SOLIDWORKS CAM Standard tools that are included with SOLIDWORKS Premium software. This integrated CAM system, makes it easier for designers to learn and understand how components are machined and automatically create and update toolpaths when design changes are made.

Model-Based Definition Production

SOLIDWORKS MBD software is an integrated 3D manufacturing solution for SOLIDWORKS that replaces and eliminates paper 2D manufacturing drawings. The application helps manufacturers quickly and easily define, organize, and publish 3D product manufacturing information (PMI), including 3D model data, in industry-standard file formats, such as eDrawings, 3D PDF, and STP242. Unlike traditional 2D drawings, SOLIDWORKS MBD software guides the manufacturing process directly in 3D, which helps streamline production, cut cycle time, reduce errors, and support industry standards.

CONCLUSION

As a leading 3D design technology provider, SOLIDWORKS understands the importance of helping designers, engineers, and manufacturing specialists work smarter and more efficiently to develop better products and help their companies maintain a competitive edge. That's why the company has been building an integrated smart manufacturing ecosystem with integrated SOLIDWORKS Premium CAD data as its cornerstone.

With SOLIDWORKS Premium design software's integration with downstream engineering and manufacturing applications, you can take advantage of a fully integrated, design-to-manufacturing process solution that allows you to bring better products to market faster and at lower cost through greater collaboration and automation. With integrated tools using 3D CAD data to drive every function from concept through production, your organization will save time, control costs, and produce higher-quality, more innovative products, all of which will help your company succeed.

To learn more about how the SOLIDWORKS 3D design-to-manufacturing software can improve your injection-molded part design, tooling development, and production processes, visit www.solidworks.com or call 1 800 693 9000 or 1 781 810 5011.

Our 3DEXPERIENCE® platform powers our brand applications, serving 12 industries, and provides a rich portfolio of industry solution experiences.

Dassault Systèmes, the 3DEXPERIENCE® Company, provides business and people with virtual universes to imagine sustainable innovations. Its world-leading solutions transform the way products are designed, produced, and supported. Dassault Systèmes' collaborative solutions foster social innovation, expanding possibilities for the virtual world to improve the real world. The group brings value to over 220,000 customers of all sizes in all industries in more than 140 countries. For more information, visit www.3ds.com.



©2018 Dassault Systèmes. All rights reserved. 3DEXPERIENCE®, the Compass icon, the 3DS logo, CATIA, SOLIDWORKS, ENOVIA, DELMIA, SIMULIA, GEOVIA, EXALTED, 3D VIA, 3DSWYX, BIOVIA, NETVIBES, IFME and 3DEXACTE are commercial trademarks or registered trademarks of Dassault Systèmes, a French "société européenne" (Versailles Commercial Register # B 322 306 440), or its subsidiaries in the United States and/or other countries. All other trademarks are owned by their respective owners. Use of any Dassault Systèmes or its subsidiaries trademarks is subject to their express written approval.



SIM Technologies Pvt. Ltd.

3rd Floor, "Mamanje Centre",
S7-A, Thiru-Vi-Ka Industrial Estate,
Guindy, Chennai – 600 032

☎ +91-8754447021

✉ marketing@simtek.in