

# UNDERSTANDING NONLINEAR ANALYSIS

White Paper

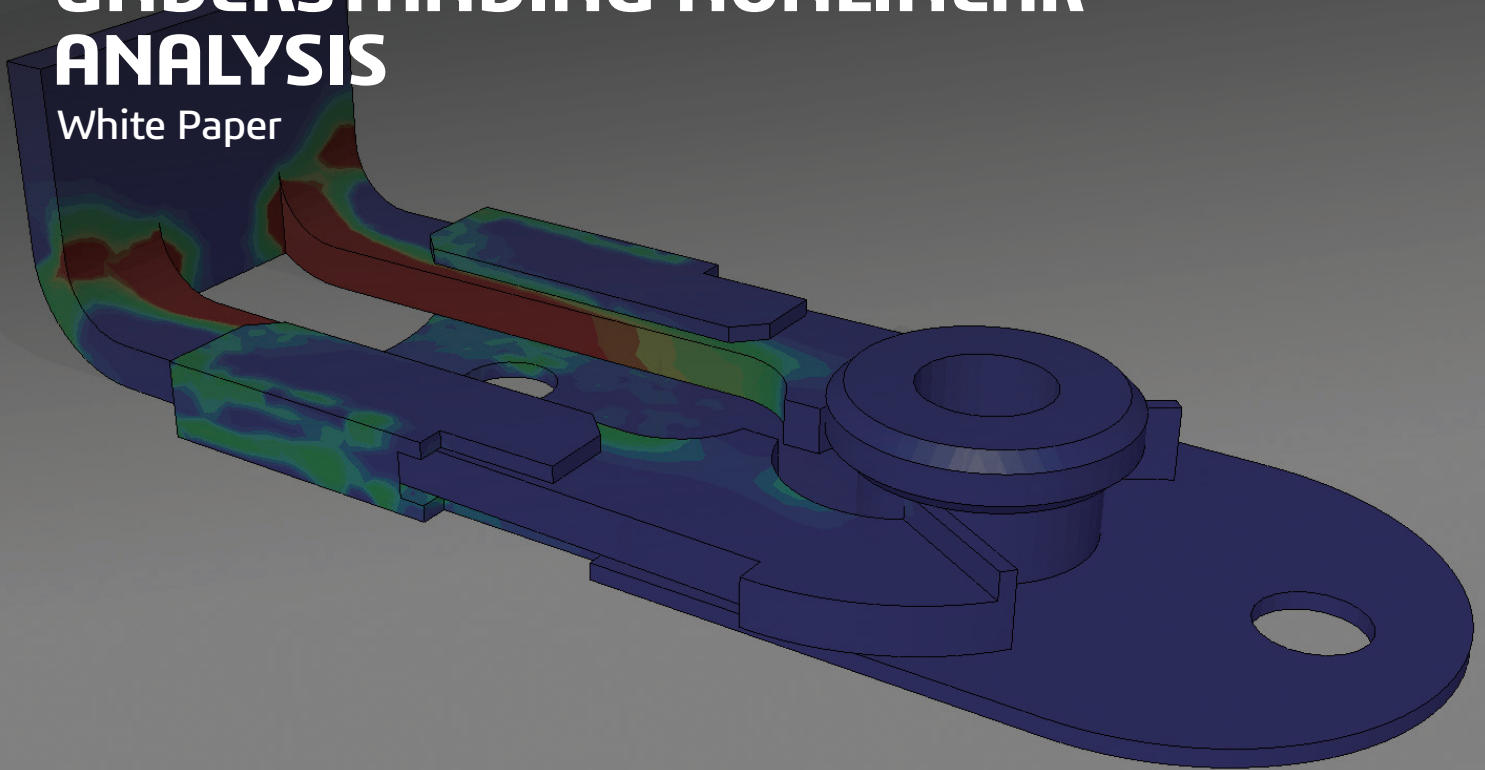

## OVERVIEW

In this paper you will learn about the differences between linear and nonlinear analysis and realize there are optimum times to use one type of analysis versus the other. We will discover that neglecting nonlinear effects can lead to serious design errors. After reviewing the examples taken from everyday design practice, you will see how nonlinear analysis can help you avoid overdesign and build better products.

# TABLE OF CONTENTS

## **P.1**

INTRODUCTION

## **P.3**

NONLINEAR GEOMETRY

## **P.4**

NONLINEAR MATERIAL

## **P.8**

LOSS OF ELASTICITY

## **P.9**

CONTACT STRESSES AND  
NONLINEAR SUPPORT

## **P.10**

NONLINEAR DYNAMIC ANALYSIS

## **P.11**

NONLINEAR ANALYSIS IN  
EVERYDAY PRACTICE

## **P.14**

CONCLUSION

## INTRODUCTION

Over the last decade, finite element analysis (FEA) stopped being regarded only as an analyst's tool and entered the practical world of design engineering. CAD software now comes with built-in FEA capabilities and design engineers use FEA as an everyday design tool in support of the product design process.

However, until recently, most FEA applications undertaken by design engineers were limited to linear analysis. Such linear analysis provides an acceptable approximation of real-life characteristics for most problems design engineers encounter. Nevertheless, occasionally more challenging problems arise, problems that call for a nonlinear approach.

Historically, engineers were reluctant to use nonlinear analysis, because of its complex problem formulation and long solution time. That's changing now, as nonlinear FEA software interfaces with CAD and has become much easier to use. In addition, improved solution algorithms and powerful desktop computers have shortened solution times. A decade ago, engineers recognized FEA as a valuable design tool. Now they are starting to realize the benefits and greater understanding that nonlinear FEA brings to the design process.

The term "stiffness" defines the fundamental difference between linear and nonlinear analysis. Stiffness is a property of a part or assembly that characterizes its response to the applied load. Three primary factors affect stiffness: shape, material, and part support.

### Differences between linear and nonlinear analysis

The term "stiffness" defines the fundamental difference between linear and nonlinear analysis. Stiffness is a property of a part or assembly that characterizes its response to the applied load. A number of factors affect stiffness:

1. Shape: An I-beam has different stiffness from a channel beam.

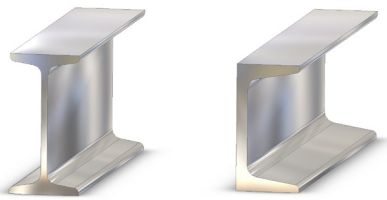

2. Material: An iron beam is less stiff than the same size steel beam.

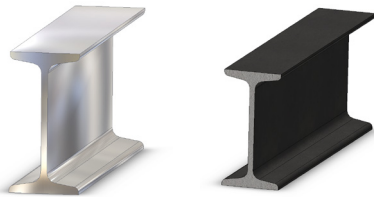

3. Part Support: A beam with a simple support is less stiff and will deflect more than the same beam with built-in supports as shown in Figure 1.

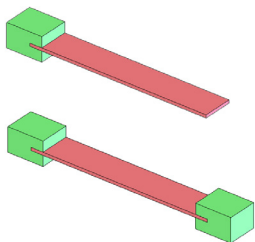

Figure 1: Cantilever beam (top) has lower stiffness than the same beam supported on both ends (bottom).

When a structure deforms under a load its stiffness changes, due to one or more of the factors listed above. If it deforms a great deal, its shape can change. If the material reaches its failure limit, the material properties will change.

On the other hand, if the change in stiffness is small enough, it makes sense to assume that neither the shape nor material properties change at all during the deformation process. This assumption is the fundamental principle of linear analysis.

That means that throughout the entire process of deformation, the analyzed model retained whatever stiffness it possessed in its undeformed shape prior to loading. Regardless of how much the model deforms, whether the load gets applied in one step or gradually, and no matter how high the stresses that develop in response to that load may be, the model retains its initial stiffness.

This assumption greatly simplifies problem formulation and solution. Recall the fundamental FEA equation:

$$[F] = [K] * [d]$$

where:

**[F] is the known vector of nodal loads**

**[K] is the known stiffness matrix**

**[d] is the unknown vector of nodal displacements**

This matrix equation describes the behavior of FEA models. It contains a very large number of linear algebraic equations, varying from several thousand to several million depending on the model size. The stiffness matrix [K] depends on the geometry, material properties, and restraints. Under the linear analysis assumption that the model stiffness never changes, those equations are assembled and solved just once, with no need to update anything while the model is deforming. Thus linear analysis follows a straight path from problem formulation to completion. It produces results in a matter of seconds or minutes, even for very large models.

Everything changes upon entering the world of nonlinear analysis, because nonlinear analysis requires engineers to abandon the assumption of constant stiffness. Instead, stiffness changes during the deformation process and the stiffness matrix [K] must be updated as the nonlinear solver progresses through an iterative solution process. Those iterations increase the amount of time it takes to obtain accurate results.

If the change in stiffness is small enough, it makes sense to assume that neither the shape nor material properties change at all during the deformation process. This assumption is the fundamental principle of linear analysis.

## UNDERSTANDING DIFFERENT TYPES OF NONLINEAR BEHAVIOR

Although the process of changing stiffness is common to all types of nonlinear analyses, the origin of nonlinear behavior can be different, making it logical to classify nonlinear analyses based on the principal origin of nonlinearity. Because it isn't possible to point out a single cause of nonlinear behavior in many problems, some analyses may have to account for more than one type of nonlinearity.

### Nonlinear geometry

As already discussed, nonlinear analysis becomes necessary when the stiffness of the part changes under its operating conditions. If changes in stiffness come only from changes in shape, nonlinear behavior is defined as geometric nonlinearity.

Such shape-caused changes in stiffness can happen when a part has large deformations that are visible to the naked eye. A generally accepted rule of thumb suggests conducting a nonlinear geometry analysis if the deformations are larger than 1/20th of the part's largest dimension. Another important factor to recognize is that in cases of large deformations, the load direction can change as the model deforms. Most FEA programs offer two choices to account for this direction change: following and nonfollowing loads.

A following load retains its direction in relation to the deformed model as shown in Figure 3. A nonfollowing load retains its initial direction.

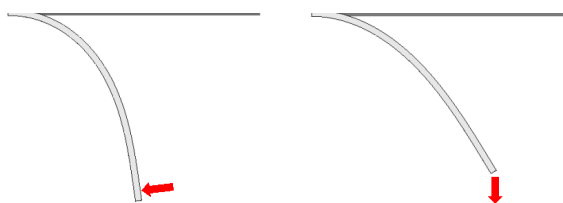

Figure 3: Following, or nonconservative, load changes its direction during the process of deformation and remains normal to the deformed beam (left). Nonfollowing, or conservative, load retains its original direction (right).

A pressure vessel subjected to very high pressure that undergoes a drastic change of shape provides another good example of the latter situation. The pressure load always acts normal to the walls of the pressure vessel. While linear analysis of this scenario assumes that the shape of the vessel does not change, realistic analysis of the pressure vessel requires analyzing geometric nonlinearity with nonconservative (or following) loading.

A generally accepted rule of thumb suggests conducting a nonlinear geometry analysis if the deformations are larger than 1/20th of the part's largest dimension. Another important factor to recognize is that in cases of large deformations, the load direction can change as the model deforms.

Changes in stiffness due to shape can also occur when the deformations are small. A typical example is an initially flat membrane deflecting under pressure (see Figure 4).

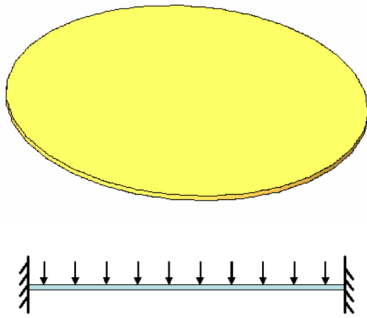

Figure 4: Analysis of a flat membrane under pressure load requires nonlinear geometry analysis even though the magnitude of deformation may be very small.

Initially, the membrane resists the pressure load only with bending stiffness. After the pressure load has caused some curvature, the deformed membrane exhibits stiffness additional to the original bending stiffness (Figure 5). Deformation changes the membrane stiffness so that the deformed membrane is much stiffer than the flat membrane.

Some FEA programs use confusing terminology, calling all analysis of geometric nonlinearities “large deformation analysis.” This ignores the necessity to perform nonlinear analysis for smaller deformation.

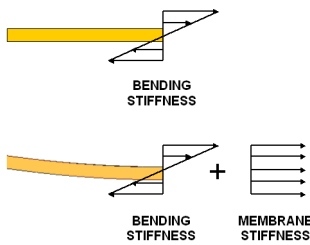

Figure 5: A flat membrane responds to load only with bending stiffness. Because of deformation it also acquires membrane stiffness. Therefore, it is much stiffer than predicted by linear analysis.

## Nonlinear material

If changes of stiffness occur due only to changes in material properties under operating conditions, the problem is one of material nonlinearity. A linear material model assumes stress to be proportional to strain (Figure 6, below). That means it assumes that the higher the load applied, the higher the stresses and deformation will be, proportional to the changes in the load. It also assumes that no permanent deformations will result, and that once the load has been removed the model will always return to its original shape.

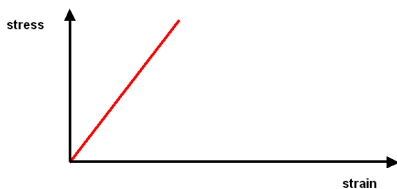

Figure 6

Changes in stiffness due to shape can also occur when the deformations are small. A typical example is an initially flat membrane deflecting under pressure. Initially, the membrane resists the pressure load only with bending stiffness. After the pressure load has caused some curvature, the deformed membrane exhibits stiffness additional to the original bending stiffness.

Although this simplification is acceptable, if the loads are high enough to cause some permanent deformations, as is the case with most plastics, or if the strains are very high (sometimes > 50 percent), as occurs with rubbers and elastomers, then a nonlinear material model must be used.

Due to the vast differences in how various types of materials behave under their operating conditions, FEA programs have developed specialized techniques and material models to simulate these behaviors. The table below offers a short review of what material models work best for which problem.

| <b>MATERIAL CLASSIFICATION</b>     | <b>MODEL</b>                         | <b>COMMENTS</b>   |
|------------------------------------|--------------------------------------|---|
| Elastoplastic                      | Von Mises or Tresca                  | These models work well for material for which a strain-stress curve shows a 'plateau' before reaching the ultimate stress. Most engineering metals and some plastics are well-characterized by this material model.                             |
|                                    | Drucker-Prager                       | This model works for soils and granular materials.  |
| Hyperelastic                       | Mooney-Rivlin and Ogden              | Work well for incompressible elastomers such as rubber.   |
|                                    | Blatz-Ko                             | This model works for compressible polyurethane foam rubbers.  |
| Viscoelastic                       | Several (optional with other models) | This model works for hard rubber or glass.  |
| Creep                              | Several (optional with other models) | Creep is a time-depedent strain produced under a state of constant stress. Creep is observed in most engineering materials, especially metals at elevated temperatures, high polymer plastics, concrete, and solid propellant in rocket motors. |
| Superelastic (Shape memory alloys) | Nitinol                              | Shape memory alloys (SMA) such as Nitinol present the superelastic effect. This material undergoes large deformations in loading-unloading cycles without showing permanent deformations.   |

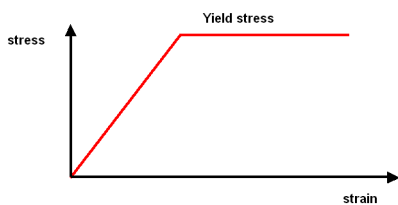
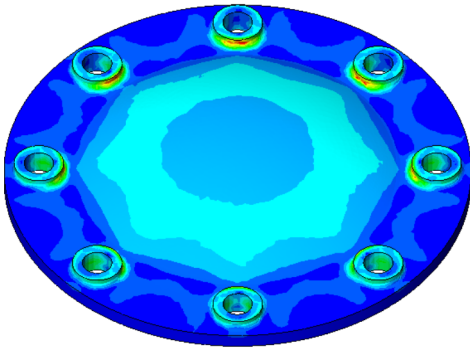

Figure 7: Stress-strain curve of an elastic-perfectly plastic material model. With this material model the maximum stress magnitude can't exceed the limit of plastic stress (yield stress).

In dealing with analysis of an elastic-perfectly plastic material model—that is, a material that has lost all ability to return to its original shape after deformation—the stress remains constant above a certain strain value. It describes the cast iron material of a bulkhead held in place very well by eight bolts.

Linear analysis reveals a maximum von Mises stress of 614 MPa (89,600 psi) as compared to a material yield of 206 MPa (30,000 psi). The results of that linear analysis are shown in Figure 8.



In dealing with analysis of an elastic-perfectly plastic material model—that is, a material that has lost all ability to return to its original shape after deformation—the stress remains constant above a certain strain value.

Figure 8: Linear stress solution of a bulkhead shows very high and localized stress concentrations.

If the stresses exceed yield, will the bulkhead fall apart? To find out, an elastoplastic material model needs to be used for examining how much material will go plastic. Figure 9 shows the nonlinear solution where the maximum stress equals the yield stress. Plastic zones are still local, indicating that the bulkhead will not fall apart. Of course, careful engineering judgment is required to decide if this design is acceptable.

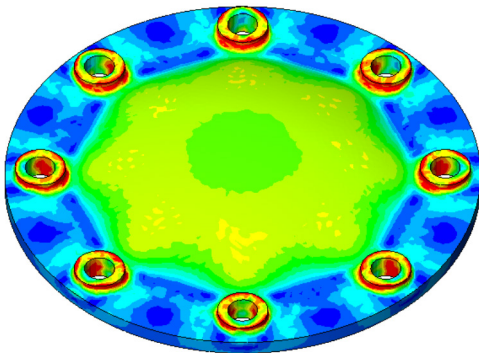
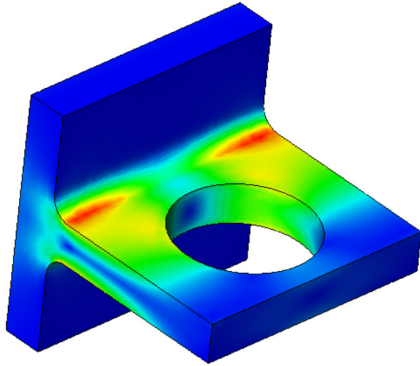

Figure 9: Nonlinear stress solution obtained with an elastic-perfectly plastic material model. Red zones indicate material going plastic. The extent of plastic zones is local.



Figure 10 shows the linear stress solution of an aluminum bracket. The maximum stress reads 44 MPa (6,400 psi) and ignores the fact that the material yields at 28 MPa (4,100 psi).



If the stresses exceed yield, will the bulkhead fall apart? To find out, an elastoplastic material model needs to be used for examining how much material will go plastic. Plastic zones are still local, indicating that the bulkhead will not fall apart.

Figure 10: Linear stress solution of a hollow bracket reports stress way above the limit of material yield stress.

Nonlinear material analysis can account for these results, where the material yields when the maximum stress holds at 28 MPa (4,100 psi) (Figure 11). The nonlinear stress results indicate that the bracket is very close to collapsing. Plastic zones occupy almost the entire cross-section of the cantilever, and a slight increase in the load magnitude would cause the cross-section to become completely plastic and develop a plastic hinge that causes the bracket to collapse.

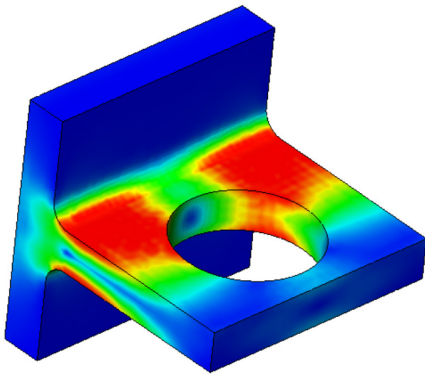

Figure 11: Nonlinear stress solution shows maximum stress not higher than yield stress. The extent of the plastic zones indicates that the bracket is very close to forming a plastic hinge. It is at the limit of load-bearing capacity.

Modeling the simple act of taking an ordinary steel paper clip, “unbending” it, and then “bending” it back, requires consideration of both nonlinear material and nonlinear geometry. Figure 12 shows the deformed shape of the paper clip using an elastic-perfectly plastic material model. Figure 13 shows residual stresses after the clip has been bent back to the original shape.

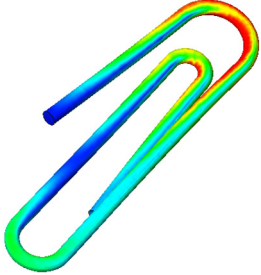

Figure 12: Analysis of paper clip bending requires nonlinear material and nonlinear geometry analysis. Paper clip in “unbent” position shows plastic stresses

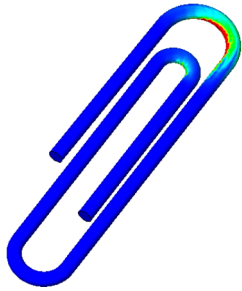

Figure 13: Paper clip bent back into the original shape shows residual stresses.

### Loss of elastic stability (buckling)

Stiffness in a part also changes due to applied loads. Sometimes, loads—depending on how they are applied—can either increase the stiffness (tension loads) or decrease it (compressive loads). For example, a tight rope can take an acrobat’s weight. A loose one, however, will make him fall. In cases of compressive load, if the changes in stiffness are sufficient to cause the structure’s stiffness to drop to zero, buckling occurs and the structure experiences a rapid deformation. It then either falls apart or acquires a new stiffness in its postbuckling state.

Linear buckling analysis can be used to calculate the load under which a structure will buckle (Euler load). However, the results of linear buckling analysis are not conservative. In addition, idealizations in the FEA model may result in the predicted buckling load being much higher for the FEA model than for the real part. Thus the results of linear buckling analysis should be used carefully.

Buckling does not necessarily equal catastrophic failure and the structure may still be able to support the load after buckling has taken place. Nonlinear analysis will explain postbuckling behavior.

Figures 13 and 14 show a snap-through effect. The part retains its load-bearing capabilities even after buckling has taken place.

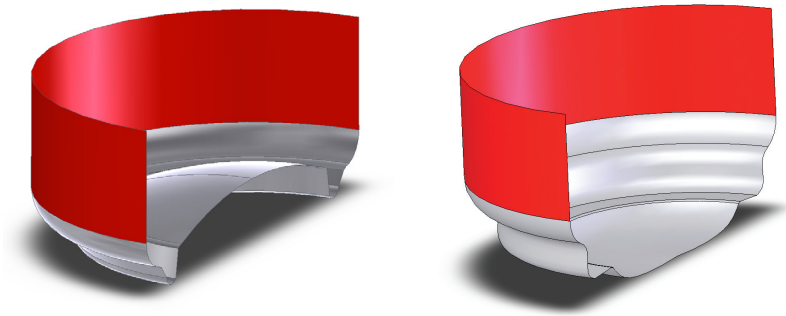

Figure 13

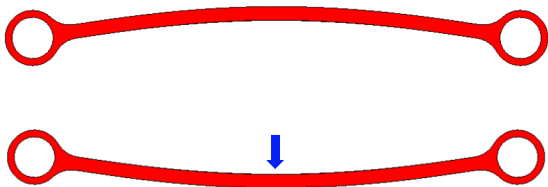

Figure 14: Analysis of snap-through effect requires nonlinear analysis.

### Contact stresses and nonlinear support

If support conditions, including contacts, change during the application of operating loads, nonlinear analysis is needed.

Contact stresses develop between two contacting surfaces. Therefore, the contact area and the stiffness of the contact zone are unknown prior to solution. Figure 15 shows a stress solution of a typical contact problem. Even though the contact stress area is very small compared to the overall model size, the changing stiffness of the contact zone calls for nonlinear analysis.

If support conditions, including contacts, change during the application of operating loads, nonlinear analysis is needed.

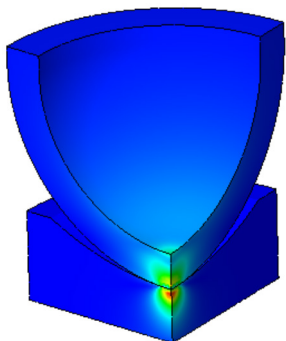

Figure 15: Contact stress analysis that models stresses developing between two spheres (only one of the two contacting parts is shown) belongs to the category of analysis with nonlinear supports.

Figure 16 shows an example of nonlinear supports. The effective beam length and its consequent stiffness depend on the amount of beam deformation. When the beam contacts the support, its stiffness increases because of the drop in its active length.

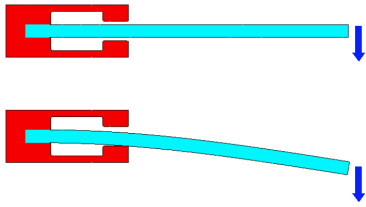

Figure 16: This support (when activated) changes the effective length of beam. Consequently, beam stiffness changes and the problem requires nonlinear analysis.

### Nonlinear dynamic analysis

Dynamic analysis accounts for inertial effects, damping, and time-dependent loads. A drop test, vibrations of an engine mount, airbag deployment, or crash simulation all require dynamic analysis. But is dynamic analysis linear or nonlinear? The qualifying rules are exactly the same as in static analysis.

If model stiffness does not change significantly under the applied load, then linear dynamic analysis suffices. A vibrating engine mount or a tuning fork both experience small deformations about the point of equilibrium and so can be analyzed with linear dynamic analysis.

Problems such as crash simulation, analysis of airbag deployment, or modeling a metal stamping process all require nonlinear dynamic analysis because both large deformations (nonlinear geometry) and large strains (nonlinear material) occur.

### How can nonlinear analysis help us build better products?

Nature is nonlinear. That means linear analysis can only approximate the real nonlinear behavior of parts and assemblies. Most of the time, such an approximation is acceptable, and linear analysis can provide valuable insight into product characteristics. In many cases, however, linear assumptions differ too much from reality and provide crude or misleading information.

Using the results of linear analysis to decide if a part will fail under its operating loads may lead to overdesign. For example, a bracket design analyzed only with linear analysis requires the designer to stick with a requirement that stress must not exceed the yield. But nonlinear analysis may show that some yielding is acceptable. In that event, it becomes possible to save on the amount of material used or to choose a less expensive material without compromising structural integrity. An engineer may be concerned about too large a deflection of a flat panel as tested with linear analysis, for another example, and overdesign it to compensate for that deflection without ever knowing that linear analysis exaggerated the deformations, and it was fine as originally designed.

In many cases, however, linear assumptions differ too much from reality and provide crude or misleading information. Using the results of linear analysis to decide if a part will fail under its operating loads may lead to over-design.

## Nonlinear analysis in everyday design practice

Once an engineer gains enough experience to recognize nonlinear problems, it becomes obvious that application of this technology isn't confined to exotic situations. Designs that require or may benefit from nonlinear analysis abound in every industry and in everyday design practice.

Here are several examples of products where the correct design decision requires nonlinear analysis. Many of these problems involve more than one type of nonlinear behavior.

### Idler pulley (Figure 17)

This stamped steel pulley may buckle under belt load before it develops excessive stresses. Although a linear buckling analysis may be enough to determine the buckling load, nonlinear analysis is required to study its postbuckling behavior.

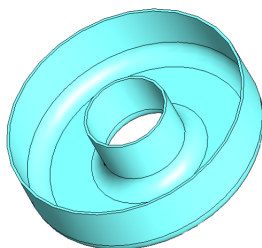

Figure 17

### Diaphragm spring (Figure 18)

The nonlinear spring characteristic requires a nonlinear geometry analysis to account for membrane effects.

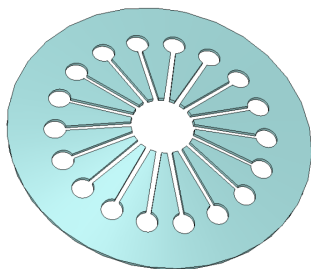

Figure 18

### Rollover protective structure (Figure 19)

In the case of a rollover, the structure deforms past its yield, and absorbs rollover energy. During this process it experiences large deformation. Understanding the effects of rollover requires combining nonlinear material and nonlinear geometry analysis.

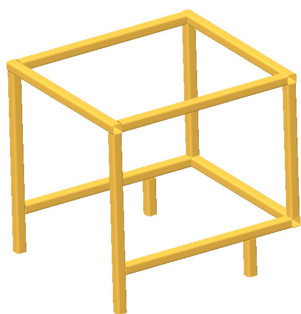

Figure 19

### Soft obstetric forceps (Figure 20)

Soft obstetric forceps are designed to “mold” around a baby’s head during forceps-assisted delivery. If too high traction and/or compression are applied, the forceps are designed to slip off the baby’s head to prevent injuries. Analysis of such forceps must combine nonlinear material and nonlinear geometry to account for large deformations and nonlinear elastic material.

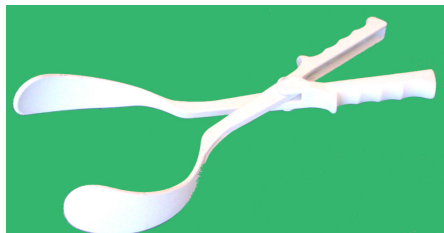

Figure 20

### Fan guard (Figure 21)

This part requires nonlinear geometry analysis because of the membrane stresses that develop during the deformation process. A nonlinear material analysis may be required as well.

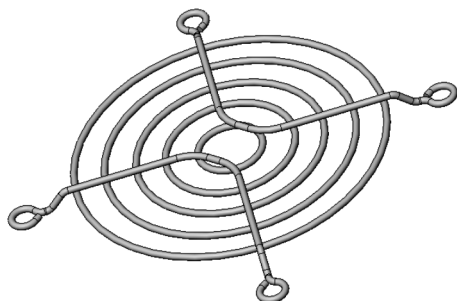

Figure 21

### Snap ring (Figure 22)

A nonlinear geometry analysis is required because of large deformations. This ring may also be a candidate for a nonlinear material analysis.



Figure 22

### Airline luggage container (Figure 23)

This airline luggage container requires a nonlinear geometry analysis because of membrane effects in the blue Lexan® panels. In addition, the frame requires a buckling or postbuckling analysis.

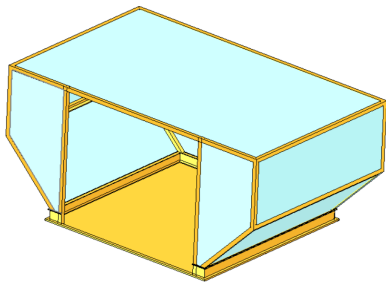

Figure 23

### Office chair (Figure 24)

In this example, large deformations of the frame may necessitate a nonlinear geometry analysis. The seat and backrest require nonlinear geometry and nonlinear material analysis.

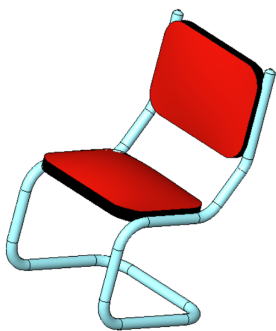

Figure 24

### Allen wrench (Figure 25)

The contact between the wrench and the socket screw necessitates a contact stress analysis.

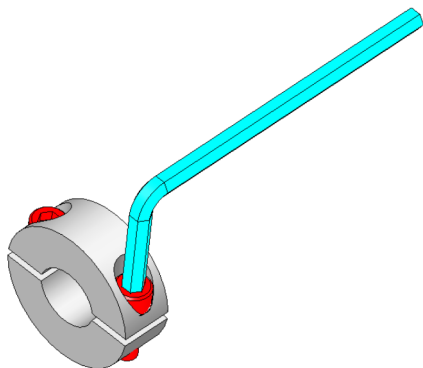

Figure 25

## CONCLUSION

The nature of encountered analysis problems should be the yardstick by which to justify a decision to add nonlinear analysis capabilities to the engineer's FEA software. If design analysis problems involve large deformations, membrane effects, nonlinear material, contact stresses, buckling, nonlinear supports or other nonlinearities, then nonlinear analysis capabilities should be added to in-house FEA software intended for use by design engineers.

The past decades have conditioned engineers to the use of FEA as a design tool. Now FEA software, computer hardware, and cloud computing have matured enough so that nonlinear analysis can be easily added to their toolboxes.

## SIMULATION SOLUTIONS FROM SOLIDWORKS

SOLIDWORKS now offers scalability and the full range of Nonlinear capabilities, from single-source to multiple Nonlinear effects for the most advanced nonlinear phenomena. SOLIDWORKS offers nonlinear capabilities in SOLIDWORKS Simulation Premium and the cloud-based SIMULIAWORKS.

**SOLIDWORKS Simulation Premium** lets you efficiently evaluate your design for nonlinear and dynamic response, dynamic loading, and composite materials and includes two advanced Nonlinear studies: Nonlinear Static and Nonlinear Dynamic. [Learn more about the SOLIDWORKS Simulation Suite here.](#)

**SIMULIAWORKS** extends SOLIDWORKS Simulation, especially for solving analysis with multiple nonlinear effects happening simultaneously and multi-step sequential loading. SIMULIAWORKS is a tightly integrated, cloud-based solution and conduct structural static, frequency, buckling, modal dynamic response, and structural-thermal analysis of parts and assemblies. Powered by SIMULIA Abaqus, the proven world-class Finite Element Analysis Solver, SIMULIAWORKS enables you to handle high complexity structural problems with confidence.

[Learn more about SIMULIAWORKS here.](#)

---

## Our 3DEXPERIENCE® platform powers our brand applications, serving 11 industries, and provides a rich portfolio of industry solution experiences.

Dassault Systèmes, the 3DEXPERIENCE® Company, provides business and people with virtual universes to imagine sustainable innovations. Its world-leading solutions transform the way products are designed, produced, and supported. Dassault Systèmes' collaborative solutions foster social innovation, expanding possibilities for the virtual world to improve the real world. The group brings value to over 250,000 customers of all sizes in all industries in more than 140 countries. For more information, visit [www.3ds.com](http://www.3ds.com).



3DEXPERIENCE®

©2019 Dassault Systèmes. All rights reserved. 3DEXPERIENCE®, the COMPASS icon, the 3DS logo, CATIA, SOLIDWORKS, ENOVIA, DELMIA, SIMULIA, GEOPM, EXALEAD, 3D VIA, 3DSWMM, BIOVIA, NETVIBES, IPWE and 3DEXPTE are commercial trademarks or registered trademarks of Dassault Systèmes, a French "société européenne" (Versailles Commercial Register # B 322 306 440), or its subsidiaries in the United States and/or other countries. All other trademarks are owned by their respective owners. Use of any Dassault Systèmes or its subsidiaries trademarks is subject to their express written approval.



## SIM Technologies Pvt. Ltd.

3rd Floor, "Mamanjee Centre",  
S7-A, Thiru-Vi-Ka Industrial Estate,  
Guindy, Chennai – 600 032

+91-8754447021

marketing@simtek.in